

WTB1 Throughbolt Anchor

High performance corrosion resistant expansion anchor for cracked concrete

Anchor types



WTB1 8x80
WTB1 8x100
WTB1 8x115
WTB1 10x95
WTB1 10x115
WTB1 10x130
WTB1 12x120
WTB1 12x135
WTB1 16x140

- The **WTB1** throughbolts are torque-controlled corrosion-resistant through-fixings for medium to heavy loads. They are approved for use in cracked and non-cracked concrete.

Features and benefits

- ETA Option 1 approval for cracked and non-cracked concrete
- Zinc-flake coated for improved corrosion resistance
- Two embedment depths provide installation flexibility
- Fire resistance class R30-R120 for design of anchorages under exposure to fire
- High load capacity
- Pre- and through fixing

Approvals and certificates

- European Technical Assessment
- Fire Test Report

ETA-17/0345, 12 April 2017
ETA-17/0345, 12 April 2017



Suitable base materials

- Non-cracked concrete, C20/25 to C50/60
- Cracked concrete, C20/25 to C50/60
- Stone

Typical applications

- Structural steel
- Barriers and safety systems
- Heavy plant machinery
- Façade systems
- Cladding

Product details

Article	Description	Size	Length	Max. fixture thickness ¹⁾	Fixture hole clearance
		[-]	L [mm]	t _{fix,max} [mm]	d _f [mm]
609831080	WTB1 8x80	M8	80	30 / 15	9
609831081	WTB1 8x100	M8	100	50 / 35	9
609831082	WTB1 8x115	M8	115	65 / 50	11
609831100	WTB1 10x95	M10	95	35 / 15	11
609831101	WTB1 10x115	M10	115	55 / 35	11
609831102	WTB1 10x130	M10	130	70 / 50	11
609831120	WTB1 12x120	M10	120	45 / 25	13
609831121	WTB1 12x135	M12	135	60 / 40	13
609831160	WTB1 16x140	M16	140	40 / 20	18

1) Max. fixture thickness is indicated at reduced / standard embedment depths

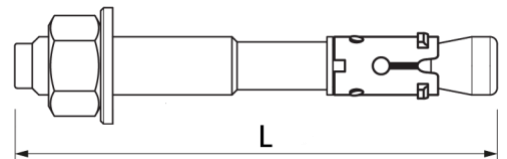

Packaging details

Article	Description	Pack 1		Pack 2	
		[pcs]	EAN13	[pcs]	EAN13
609831080	WTB1 8x80	100	8712993156726	-	-
609831081	WTB1 8x100	50	8712993156733	-	-
609831082	WTB1 8x115	50	8712993156740	-	-
609831100	WTB1 10x95	50	8712993156757	-	-
609831101	WTB1 10x115	50	8712993156764	-	-
609831102	WTB1 10x130	50	8712993156771	-	-
609831120	WTB1 12x120	50	8712993156788	-	-
609831121	WTB1 12x135	50	8712993156795	-	-
609831160	WTB1 16x140	25	8712993156801	-	-

Mechanical properties

Component	Material
Anchor body	Steel rod on coil cold forged bolts. Steel grade C17C, according EN 10263-2.
Expansion sleeve	Steel grade DC03, M8-M12 C590, M16-M20 C490
Hexagonal nut	According DIN 934
Washer	According DIN 125A or DIN 9021

Component	Material properties	
Anchor body	M8 - M16	
Ultimate tensile strength [N/mm ²]	430 - 480	
Expansion sleeve	M8 - M12	M16
Hardness [HV]	185 - 215	155 - 185

Installation parameters

Anchor Type		WTB1			
Anchor Size		M8	M10	M12	M16
Drill hole diameter	d_0 [mm]	8	10	12	16
Installation torque	T_{inst} [Nm]	10	20	40	100
Wrench Size	SW [mm]	13	17	19	24
Standard embedment depth					
Depth of drill hole	h_0 [mm]	55	69	80	100
Nominal embedment depth	h_{nom} [mm]	55	69	80	100
Min. concrete member thickness	h_{min} [mm]	100	120	140	170
Min. edge distance in cracked concrete	C_{min} [mm]	40	45	65	90
Min. edge distance in non-cracked concrete	C_{min} [mm]	40	50	65	100
Min. anchor spacing in cracked concrete	S_{min} [mm]	50	70	90	160
Min. anchor spacing in non-cracked concrete	S_{min} [mm]	50	70	90	160
Reduced embedment depth					
Depth of drill hole	h_0 [mm]	40	49	60	80
Nominal embedment depth	h_{nom} [mm]	40	49	60	80
Min. concrete member thickness	h_{min} [mm]	100	100	100	130
Min. edge distance in cracked concrete	C_{min} [mm]	40	50	80	110
Min. edge distance in non-cracked concrete	C_{min} [mm]	45	60	100	125
Min. anchor spacing in cracked concrete	S_{min} [mm]	55	75	150	190
Min. anchor spacing in non-cracked concrete	S_{min} [mm]	55	75	150	190

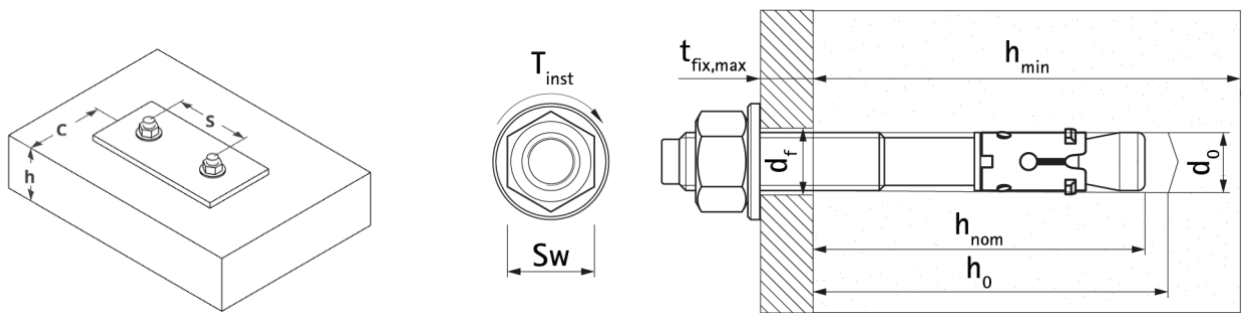

Instructions for installation in concrete

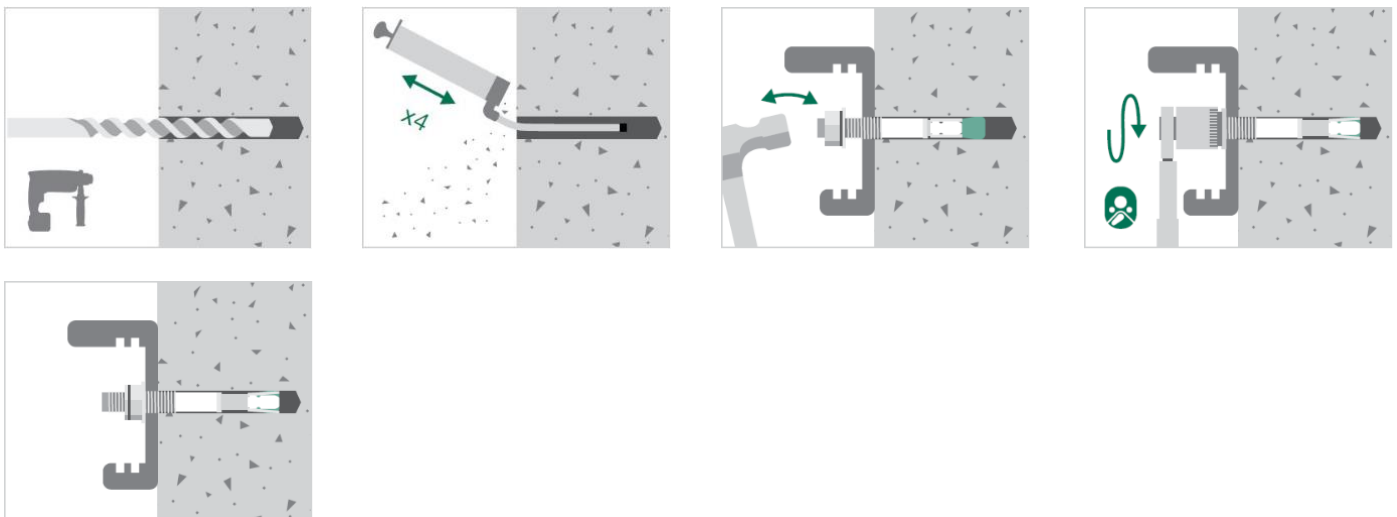

Recommended loads in C20/25 concrete for single anchors¹⁾

Anchor Type			WTB1				
Anchor size			M8	M10	M12	M16	
Standard embedment depth	h_{nom}	[mm]	55	69	80	100	
Reduced embedment depth	h_{nom}	[mm]	40	49	60	80	
Tension							
Non-cracked concrete	$h_{nom} = \text{standard}$	N_{Rec}	[kN]	3.57	5.71	9.52	16.67
	$h_{nom} = \text{reduced}$	N_{Rec}	[kN]	2.98	3.57	5.71	12.60
Cracked concrete	$h_{nom} = \text{standard}$	N_{Rec}	[kN]	1.98	4.29	5.71	9.52
	$h_{nom} = \text{reduced}$	N_{Rec}	[kN]	1.19	2.38	4.29	7.62
Shear							
Non-cracked concrete	$h_{nom} = \text{standard}$	V_{Rec}	[kN]	5.77	9.14	13.31	24.57
	$h_{nom} = \text{reduced}$	V_{Rec}	[kN]	3.63	4.88	8.00	24.57
Cracked concrete	$h_{nom} = \text{standard}$	V_{Rec}	[kN]	4.60	7.77	13.31	24.57
	$h_{nom} = \text{reduced}$	V_{Rec}	[kN]	2.59	3.48	5.70	17.97

1) Single anchors are anchors not affected by concrete edge and anchor spacing influence.

2) Recommended load includes partial safety factor and an overall partial safety factor for action of 1.4. The partial safety factor for action depends on the type of loading and shall be taken from national regulations. All anchor failure modes and the entire relevant product European Technical Assessment must be considered for anchor design.

Characteristic values of resistance to tension load under fire exposure¹⁾

Anchor Type			WTB1							
Anchor Size			M8		M10		M12		M16	
Nominal embedment depth	h_{nom}	[mm]	40	55	49	69	60	80	80	100
R30										
Steel failure	$N_{Rk,s,fi}$	[kN]	0.40	0.40	0.90	0.90	1.70	1.70	3.10	3.10
Pull-out failure	$N_{Rk,s,fi}$	[kN]	0.80	1.30	1.50	2.30	2.30	3.00	4.00	5.00
Concrete cone failure	$N_{Rk,c,fi}$	[kN]	1.00	2.70	1.70	4.80	2.90	6.90	6.10	12.00
R60										
Steel failure	$N_{Rk,s,fi}$	[kN]	0.30	0.30	0.80	0.80	1.30	1.30	2.40	2.40
Pull-out failure	$N_{Rk,s,fi}$	[kN]	0.80	1.30	1.50	2.30	2.30	3.00	4.00	5.00
Concrete cone failure	$N_{Rk,c,fi}$	[kN]	1.00	2.70	1.70	4.80	2.90	6.90	6.10	12.00
R90										
Steel failure	$N_{Rk,s,fi}$	[kN]	0.30	0.30	0.60	0.60	1.10	1.10	2.00	2.00
Pull-out failure	$N_{Rk,s,fi}$	[kN]	0.80	1.30	1.50	2.30	2.30	3.00	4.00	5.00
Concrete cone failure	$N_{Rk,c,fi}$	[kN]	1.00	2.70	1.70	4.80	2.90	6.90	6.10	12.00
R120										
Steel failure	$N_{Rk,s,fi}$	[kN]	0.20	0.20	0.50	0.50	0.80	0.80	1.60	1.60
Pull-out failure	$N_{Rk,s,fi}$	[kN]	0.60	1.00	1.20	1.80	1.80	2.40	3.20	4.00
Concrete cone failure	$N_{Rk,c,fi}$	[kN]	0.80	2.20	1.40	3.90	2.30	5.50	4.90	9.60
Critical anchor spacing distance	$S_{cr,N}$	[mm]	4 x h_{ef}							
Minimum anchor spacing distance	S_{min}	[mm]	55	50	75	70	150	90	190	160
Critical edge spacing distance	$C_{cr,N}$	[mm]	2 x h_{ef}							
Minimum edge spacing distance	C_{min}	[mm]	2 x h_{ef} ³⁾							

1) In absence of other national regulations the partial safety factor for resistance under fire exposure $\gamma_{M,fi} = 1,0$ is recommended

2) Use restricted to anchoring statically indeterminate structural components

3) If the fire attack is from more than one side, the edge distance of the anchor has to be ≥ 300 mm and $\geq 2 \times h_{ef}$

Characteristic values of resistance to shear load under fire exposure

Anchor Type			WTB1							
Anchor Size			M8		M10		M12		M16	
Nominal embedment depth	h_{nom}	[mm]	40 ¹⁾	55	49 ¹⁾	69	60	80	80	100
R30										
Steel failure without lever arm	$V_{Rk,s,fi}$	[kN]	0.40	0.40	0.90	0.90	1.70	1.70	3.10	3.10
Steel failure with lever arm	$M_{Rk,s,fi}$	[Nm]	0.40	0.40	1.10	1.10	2.60	2.60	6.70	6.70
R60										
Steel failure without lever arm	$V_{Rk,s,fi}$	[kN]	0.30	0.30	0.80	0.80	1.30	1.30	2.40	2.40
Steel failure with lever arm	$M_{Rk,s,fi}$	[Nm]	0.30	0.30	1.00	1.00	2.00	2.00	5.00	5.00
R90										
Steel failure without lever arm	$V_{Rk,s,fi}$	[kN]	0.30	0.30	0.60	0.60	1.10	1.10	2.00	2.00
Steel failure with lever arm	$M_{Rk,s,fi}$	[Nm]	0.30	0.30	0.70	0.70	1.70	1.70	4.30	4.30
R120										
Steel failure without lever arm	$V_{Rk,s,fi}$	[kN]	0.20	0.20	0.50	0.50	0.80	0.80	1.60	1.60
Steel failure with lever arm	$M_{Rk,s,fi}$	[Nm]	0.20	0.20	0.60	0.60	1.30	1.30	3.30	3.30
Factor ²⁾	k_8	[-]	1.00	1.00	1.00	1.00	1.00	2.00	2.00	2.00
Concrete edge failure			The characteristic resistance $V_{Rk,c,fi}^0$ in concrete C20/25 to C50/60 is determined by: $V_{Rk,c,fi}^0 = 0,25 \times V_{Rk,c}^0 (\leq 90)$ and $V_{Rk,c,fi}^0 = 0,20 \times V_{Rk,c}^0 (\leq 120)$ with the initial value of the characteristic resistance $V_{Rk,c}^0$ in cracked concrete C20/25 under normal temperature							

1) Use restricted to anchoring statically indeterminate structural components

2) The values of factor k_8 and relevant values of $N_{Rk,c,fi}$ given in the table *Characteristic values of resistance to tension load under fire exposure* have to be considered in the design