

Information and
assembly instruction

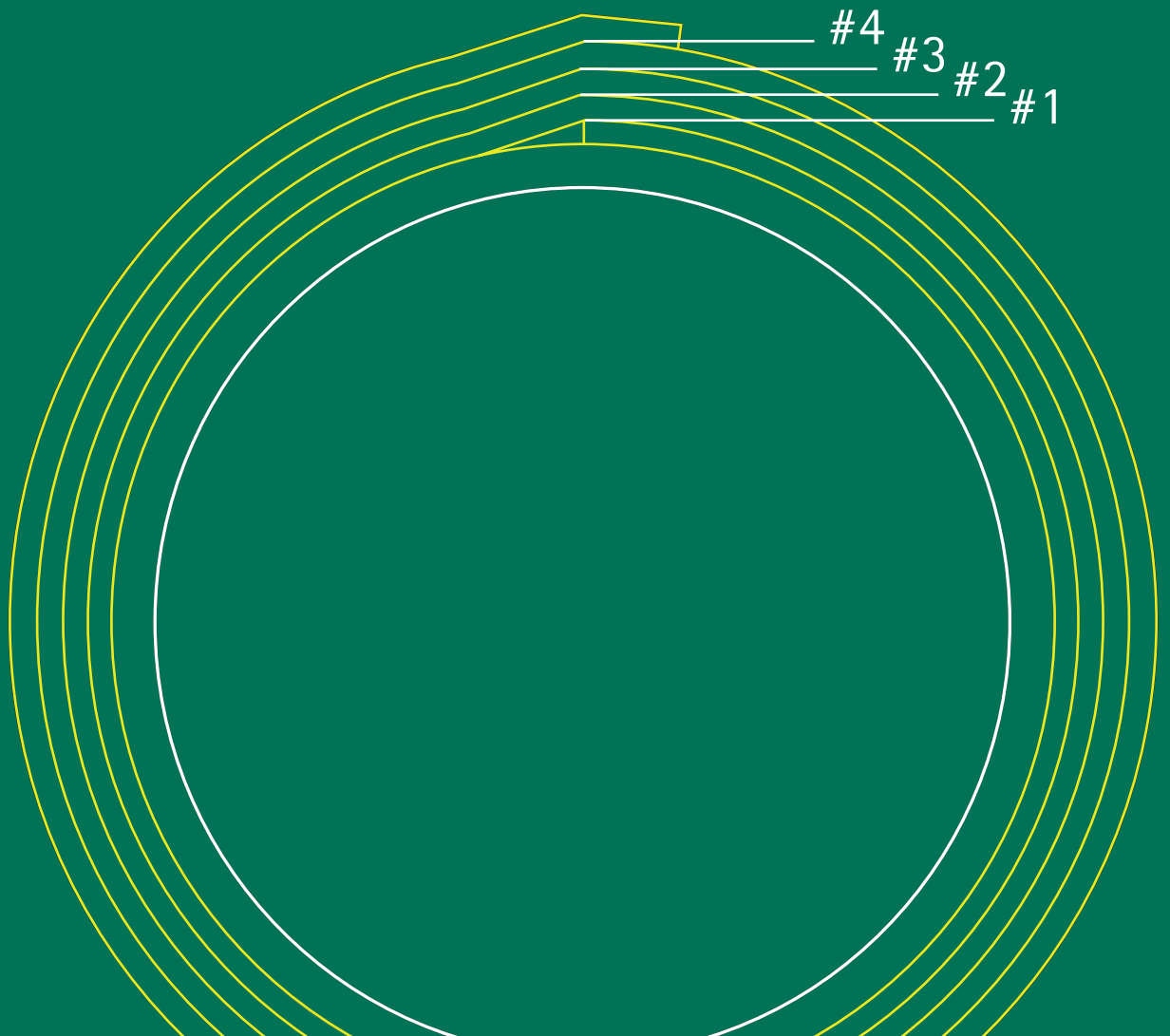

Technical Data Sheet Walraven Pacifyre[®] FPW

Walraven Pacifyre® FPW Fire Protection Wrap

Installation instruction

Easy to install

The Walraven Pacifyre® FPW Fire Protection Wrap is installed easily without using extra fixing materials. Only one pair of hands is needed for the whole installation.

After wrapping the Walraven Pacifyre® FPW around the pipe it can be slid into the right position, flush to the surface of the supporting construction.

After this the gap needs to be filled with loose mineral wool and sealed with Walraven Pacifyre® A Acrylic sealant. Fill out the Walraven Pacifyre® ID-Card and place it next to the penetration and the job is done.



1. Clean the pipe and check the dimensions.

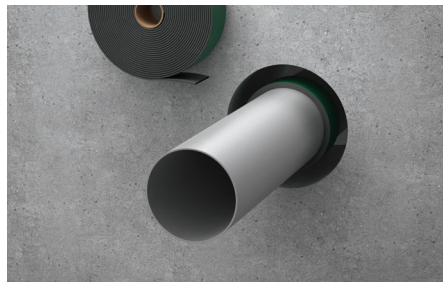

2. Wrap around the required amount of layers of Walraven Pacifyre® FPW.



3. Close the gap between the wrap and the wall/floor with loose mineral wool.



4. Seal the gap with Walraven Pacifyre® A Acrylic Sealant (t = 10 mm).



5. Flatten the Acrylic with a jointing knife or trowel.



6. Fill out and place the Walraven Pacifyre® ID Card next to the penetration.

Installation options



Combustible pipes made of different materials up to Ø 160 mm EI 120 U/U.



Multilayer pipes with and without synthetic rubber insulation up to Ø 110 mm EI 120 U/C.

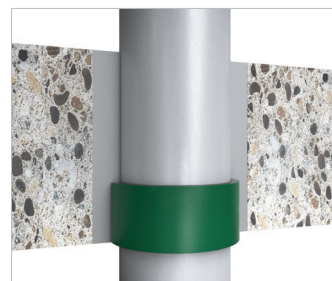

Floor penetration with an installation of the Walraven Pacifyre® FPW just on the underside.

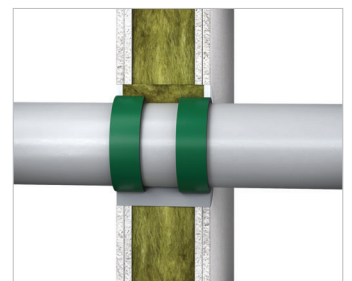

Penetration through flexible and rigid walls ≥ 100 mm.

1. General description of Walraven Pacifyre® FPW

Walraven Pacifyre® FPW Fire Protection Wrap can be installed as a penetration seal around various types of combustible pipes such as PP, PVC, PE and many more up to a diameter of Ø 160 mm. Specifications of each pipe material and dimension can be found at the application description in this technical data sheet.

The Walraven Pacifyre® FPW Fire Protection Wrap is an intumescent strip which starts expanding at a temperature above 180° C. It is provided with a self-adhesive layer to allow an easy installation.

Detailed specifications for identification and performance criteria relevant for fire safety with regard to the construction products can be found in the DoP-0761-CPR-22-0022 and the ETA-22/0022.

The verification and assessment methods on which this European Technical Assessment is based lead to the assumption of a working life of at least 25 years for the Walraven Pacifyre® FPW – Fire Protection Wrap.

Technical Data

Article number: 2122250920

Dimension L x B x s: 9200 x 50 x 2.00 mm

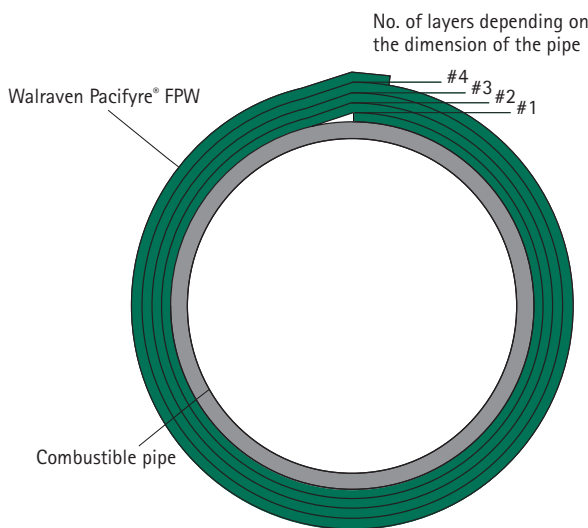

Features and benefits

- for application in flexible walls, rigid walls, and rigid floors
- suitable for combustible pipes with intended use as rainwater, sewage, gas, drinking water and heating or cooling
- for various combustible pipe materials such as PP-H, PVC and PE
- suited for certain branded pipes
- easy to install without any additional fixing material
- only 1 roll for numerous penetrations
- self adhesive
- with a fire resistance up to EI 120 U/U
- tested according to EN 1366-3 and European approval: ETA-22/022



2. Components & separating elements

Walraven Pacifyre® FPW – Fire Protection Wrap

Component name	Characteristics
Walraven Pacifyre® IM Pro	Flexible intumescent strip (provided with a self-adhesive layer) with a nominal thickness of 2.0 mm and a width of 50 mm.

Gap Fillers

Component name	Characteristics
Walraven Pacifyre® A	One component fire retardant sealant based on a water based acrylic dispersion with plasto-elastic properties - filled in cartridges.
Walraven Pacifyre® FPM	Cement based fire protection mortar, according to EN 998-2, containing Portland cement, with a nominal dry bulk density of 1620 kg/m ³ .
Loose mineral wool	Loose stone wool with a classification A1 according to EN 13501-1 with a melting point > 1000 °C (e.g., Rockwool Loose Wool).

Insulations

Component name	Characteristics
AF/Armaflex	Closed cell, flexible elastomeric foam (FEF) insulation in form of (slotted) tubes which can be provided with a self-adhesive layer. Manufactured by "Armacell GmbH".

Wall or floor constructions

Separating element	Construction
Flexible walls	<p>Steel studs or timber studs lined on both faces with minimum 2 layers of boards (minimum thickness of 12,5 mm each) or 1 layer of minimum 25 mm thickness with a classification A2-s1, d0 or A1 according to EN 13501-1.</p> <ul style="list-style-type: none"> ■ For timber stud walls, there shall be a minimum distance of 100 mm of the penetration seal to any timber stud has to be closed with min.100 mm of insulation with classification A1 or A2 according to EN 13501 -1 ■ Minimum thickness of 100 mm ■ Classification according to EN 13501-2: > EI90
Rigid walls	<ul style="list-style-type: none"> ■ Aerated concrete, concrete or masonry ■ Minimum thickness of 100 mm ■ Classification according to EN 13501-2: for the required fire resistance period.
Rigid floors	<ul style="list-style-type: none"> ■ Aerated concrete or concrete ■ Minimum density of 550 kg/m³ ■ Minimum thickness of 150 mm ■ Classification according to EN 13501-2: for the required fire resistance period

3. Service support construction

Service support construction in walls

Wall Application

All plastic and multi-layer pipes – in both flexible and rigid walls – have to be supported on both sides of the separating element by service support constructions. This construction can be made by pipe clamps, profiles, studs, bolts etc. made of metal with a melting or decomposition point greater than 1049°C (for instance stainless steel or zinc-plated steel).

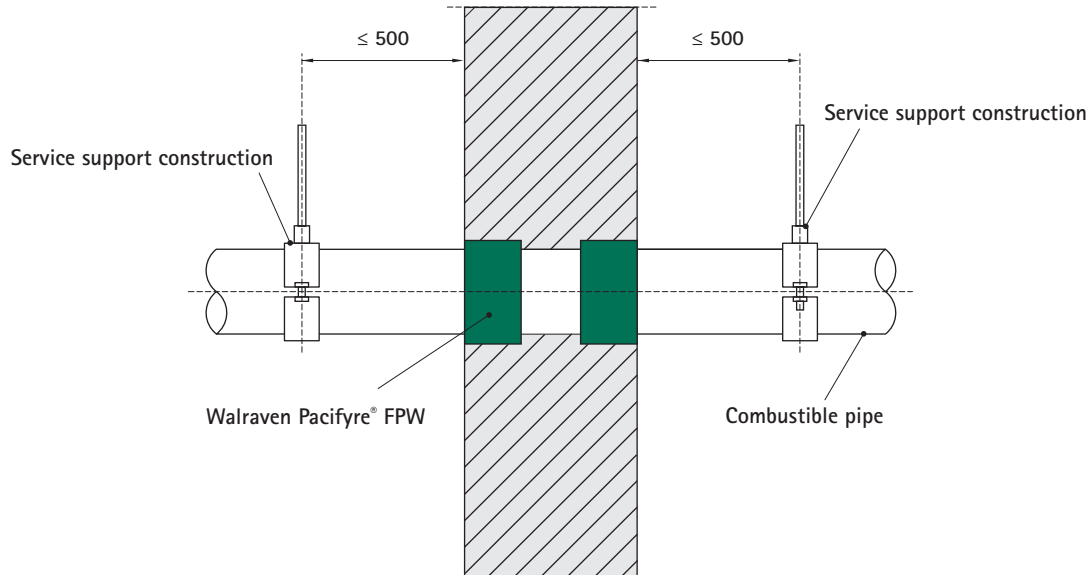

The first support for all types of pipes has to be at a maximum distance of 500 mm (measured from the surface of the wall).

Service support construction in floors

Floor Application

All plastic and multi-layer pipes – in rigid floors – have to be supported on the unexposed (top) side of the separating element by service support constructions. This construction can be made by pipe clamps, profiles, studs, bolts etc. made of metal with a melting or decomposition point greater than 1049°C (for instance stainless steel or zinc-plated steel.)

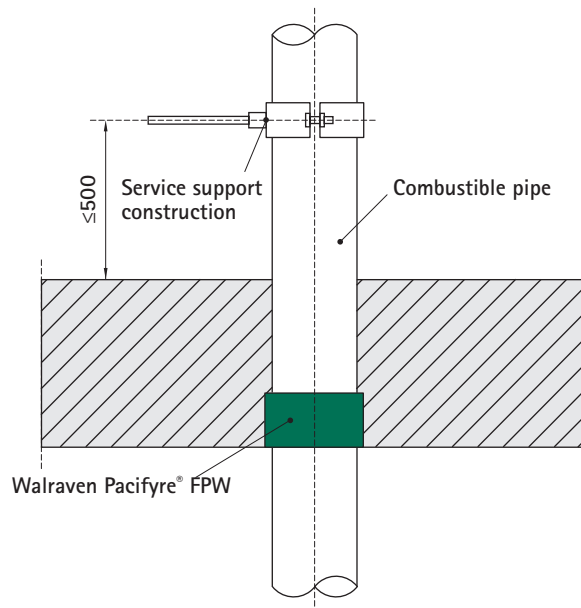

The first support for all types of pipes has to be at a maximum distance of 500 mm (measured from the surface of the floor).

4. Positioning

For plastic pipes and multi-layer pipes in vertical separating elements (walls), the Walraven Pacifyre® FPW has to be installed on both sides and flush with the surfaces of the element.

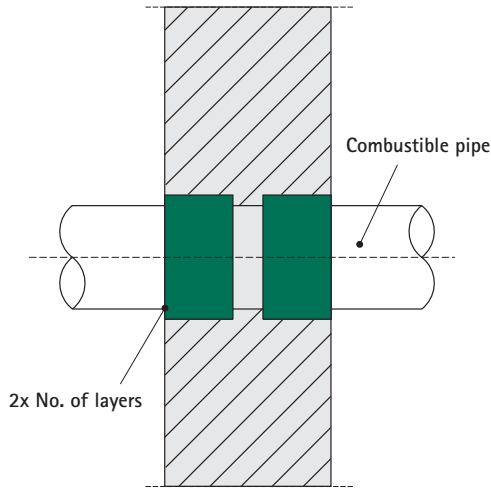

For plastic pipes and multi-layer pipes in horizontal separating elements (floors), the Walraven Pacifyre® FPW has to be installed on the bottom side and flush with the surface of the element.

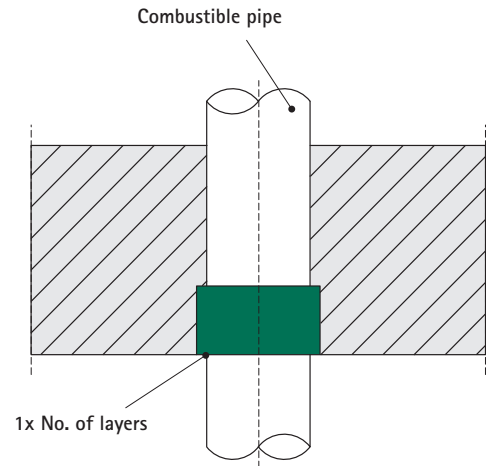

Combustible pipes | according to ETA 22/0022

Ø (mm)	Layer #	L (mm)	Nr. of penetration with one roll #
32	2	295	35
40	2	345	29
50	2	408	24
63	3	750	13
75	3	863	11
90	4	1366	7
110	4	1617	5
125	7	3314	2
140	7	3644	2
160	7	4083	2

* Check application details in this document for the maximum allowed dimension per material

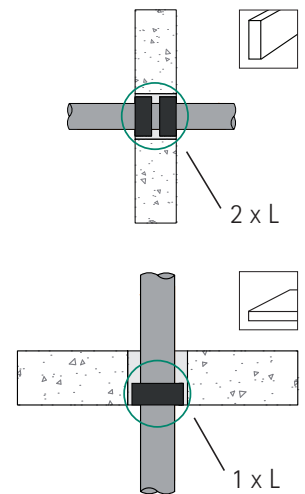

Plastic pipes with the intended use as rainwater, sewage pipe, gas, drinking water and heating pipe made out of material such as: PVC-U, PVC-C, PE, ABS, PP-H or special pipes such as Geberit Silent Pro, Georg

Fischer Silenta Premium, Conel Drain, Wavin AS+, Wavin SiTech+, POLO-KAL NG, POLO-KAL 3S, REHAU RAUPIANO and more*.

Do you struggle to know which length to cut to achieve the correct number of layers?

Check out our calculator!



5. Wall application – Gap filling

Sealant type A | Walraven Pacifyre® A Acrylic sealant with a backfilling of firmly compressed loose wool

Wall Application

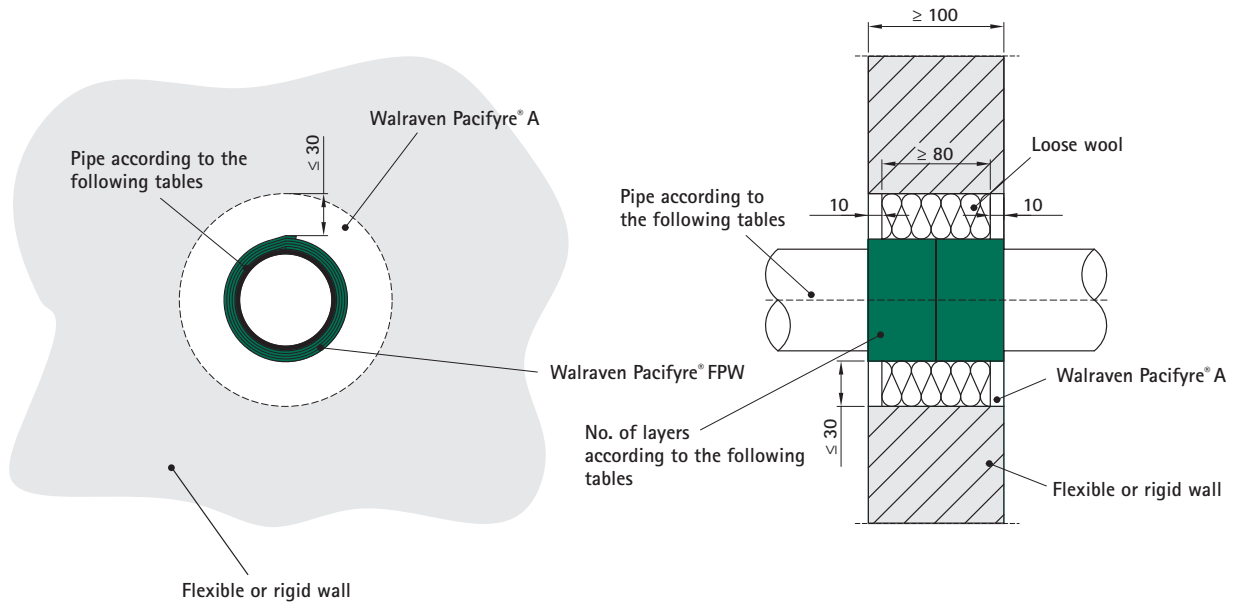

1. The backfilling is made by firmly compressed loose stone wool and fills the entire space between both layers of Walraven Pacifyre® A.

To apply the Acrylic properly the backfilling needs to be 10 mm from the surface inside the wall.

2. Filling the entire aperture with Walraven Pacifyre® A between the wrap seal and the aperture edge flush with both sides of the supporting construction (wall).

Sealant type M | Walraven Pacifyre® FPM Mortar sealant

Wall Application

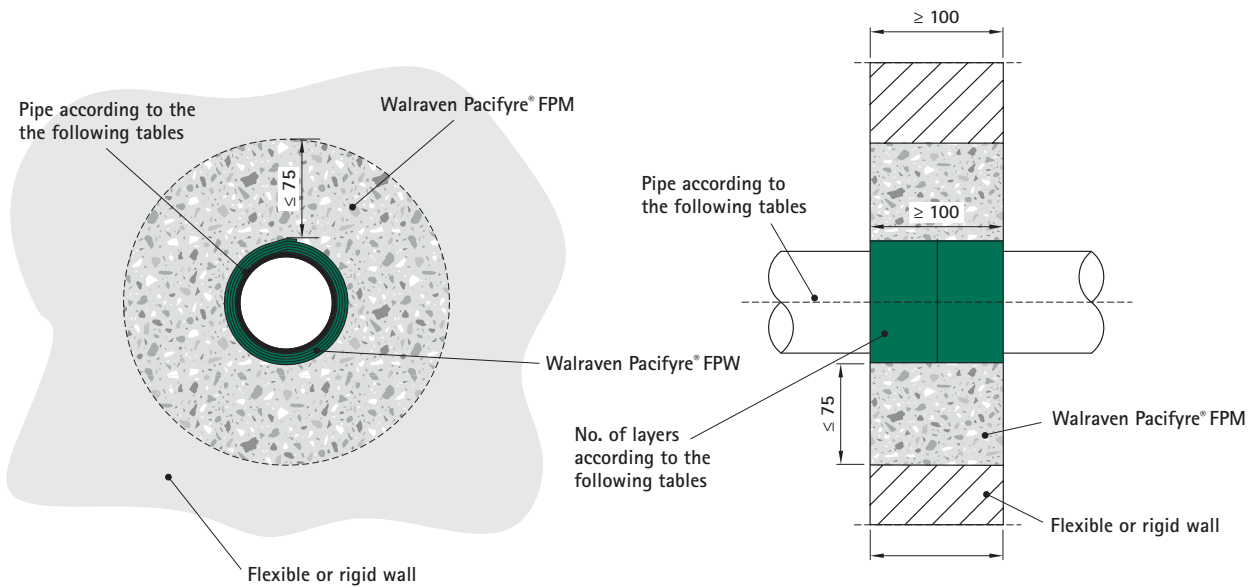

6. Wall application – type of wall (plastic pipes)

Double-sided flexible wall construction type a)

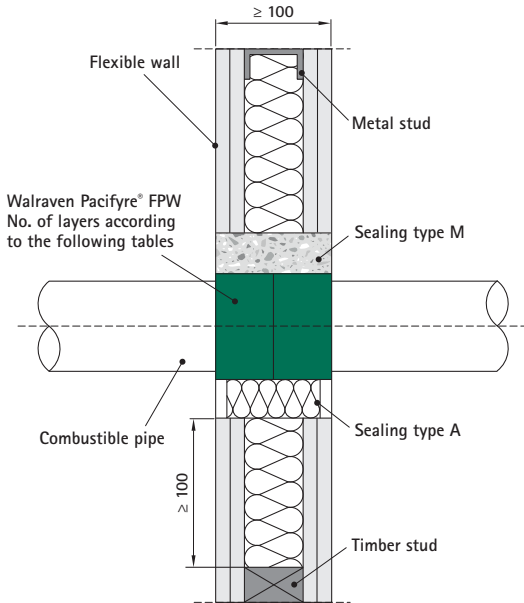

Flexible wall constructions with ≥ 2 board layers with an overall lining thickness of ≥ 25 mm (2×12.5 mm) on each side of the wall and an stone wool insulation of 50 mm with a density of ≥ 100 kg/m³.

Double-sided flexible wall construction type b)

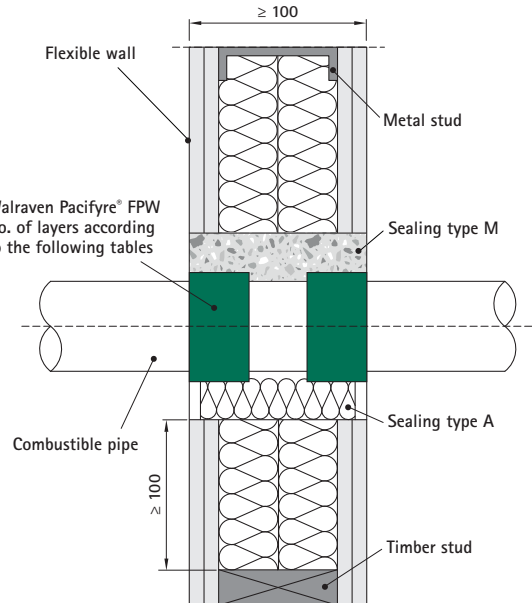

Flexible wall constructions with ≥ 2 board layers with an overall lining thickness of ≥ 25 mm (2×12.5 mm) on each side of the wall and an stone wool insulation of 50 mm with a density of ≥ 100 kg/m³.

Double-sided flexible wall construction type c)

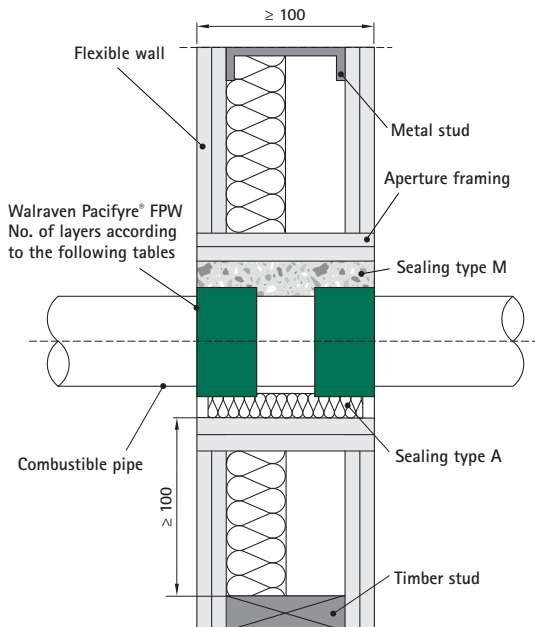

Flexible wall constructions with ≥ 2 board layers with an overall lining thickness of ≥ 25 mm (2×12.5 mm) on each side of the wall and any type of insulation.

With an aperture framing with at least 1 layer with an overall tickness of ≥ 25 mm or in case of circular apertures a dimensionally stable sleeve of materials of class A1 or A2.

Rigid wall construction type d)

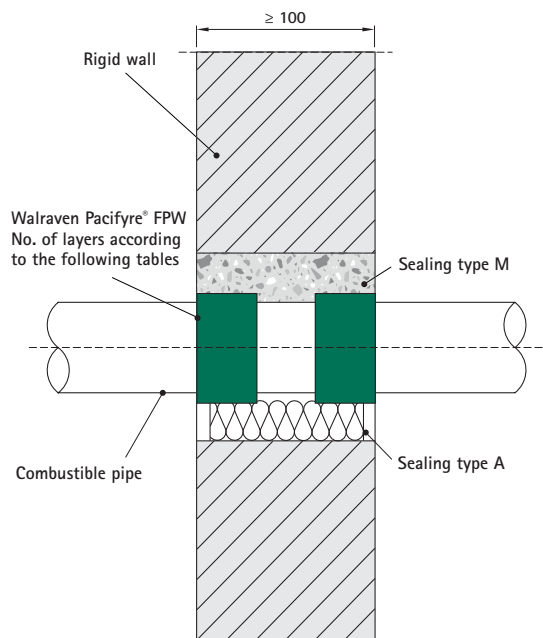

Rigid wall construction with a density of ≥ 350 kg/m³.

7. Wall application – pipe types and dimensions

Service support construction in wall

Wall Application

Plastic pipes with intended use as rainwater pipe, sewage pipe (ventilated = U/U and unventilated = U/C) and gas, drinking water and heating pipe made out of the below material and dimension:

Pipes made from PVC-U in accordance with EN-1329-1, EN 1453-1, EN ISO 15493 and EN ISO 1452-2 and PVC-C pipes in accordance with EN 1566-1, EN ISO 15493 and EN ISO 15877-2

Supporting construction	Outer-Ø	t _{pipe}	Sealant*	No. of layers	Classifications	
Flexible and rigid walls	≤ Ø 50 mm	1.8 mm	A + M	2	EI 120 U/U	E 120 U/U
	≤ Ø 50 mm	5.6 mm	A + M	2	EI 120 U/U	E 120 U/U
	≤ Ø 50 mm	1.8 – 5.6 mm	A + M	2	EI 120 U/U	E 120 U/U
	≤ Ø 75 mm	1.8 mm	A + M	3	EI 120 U/U	E 120 U/U
	≤ Ø 75 mm	8.4 mm	A + M	3	EI 120 U/U	E 120 U/U
	≤ Ø 75 mm	1.8 – 8.4 mm	A + M	3	EI 120 U/U	E 120 U/U
	≤ Ø 110 mm	2.2 mm	A + M	4	EI 120 U/U	E 120 U/U
	≤ Ø 110 mm	12.3 mm	A + M	4	EI 90 U/U	E 120 U/U
	≤ Ø 110 mm	2.2 – 12.3 mm	A + M	4	EI 90 U/U	E 120 U/U
	≤ Ø 160 mm	3.2 mm	A + M	7	EI 120 U/U	E 120 U/U
	≤ Ø 160 mm	11.8 mm	A + M	7	EI 60 U/U	E 120 U/U
	≤ Ø 160 mm	3.2 – 11.8 mm	A + M	7	EI 60 U/U	E 120 U/U

Pipes made from PE in accordance with EN-1519-1, EN 12666-1, EN 12201-2 and EN ISO 15494 and PE-X pipes in accordance with EN ISO 15785-2, ABS pipes in accordance with EN 1455-1 and EN ISO 15493 as well as SAN+PVC pipes in accordance with ISO 19220.

Supporting construction	Outer-Ø	t _{pipe}	Sealant*	No. of layers	Classifications	
Flexible and rigid walls	≤ Ø 50 mm	1.8 mm	A + M	2	EI 90 U/U	E 120 U/U
	≤ Ø 50 mm	5.6 mm	A + M	2	EI 120 U/U	E 120 U/U
	≤ Ø 50 mm	1.8 – 5.6 mm	A + M	2	EI 90 U/U	E 120 U/U
	≤ Ø 75 mm	1.8 mm	A + M	3	EI 120 U/U	E 120 U/U
	≤ Ø 75 mm	8.4 mm	A + M	3	EI 120 U/U	E 120 U/U
	≤ Ø 75 mm	1.8 – 8.4 mm	A + M	3	EI 120 U/U	E 120 U/U
	≤ Ø 110 mm	2.2 mm	A + M	4	EI 120 U/U	E 120 U/U
	≤ Ø 110 mm	12.3 mm	A + M	4	EI 120 U/U	E 120 U/U
	≤ Ø 110 mm	2.2 – 12.3 mm	A + M	4	EI 120 U/U	E 120 U/U
	≤ Ø 160 mm	3.2 mm	A + M	7	EI 120 U/U	E 120 U/U
	≤ Ø 160 mm	11.8 mm	A + M	7	EI 60 U/U	E 60 U/U
	≤ Ø 160 mm	3.2 – 11.8 mm	A + M	7	EI 60 U/U	E 60 U/U

*Explanation of sealent types see 5. Wall application – gap filling.

Service support construction in wall

Wall Application

Plastic pipes with an intended use as rainwater pipe, sewage pipe (ventilated = U/U and unventilated = U/C) and gas, drinking water and heating pipe made out of the below material and dimension:

Pipes made from PP-H in accordance with DIN 8077/78

Supporting construction	Outer-Ø	t _{pipe}	Sealant*	No. of layers	Classifications	
Flexible and rigid walls	≤ Ø 50 mm	2.0 mm	A + M	2	EI 120 U/U	E 120 U/U
	≤ Ø 50 mm	4.6 mm	A + M	2	EI 120 U/U	E 120 U/U
	≤ Ø 50 mm	2.0 – 4.6 mm	A + M	2	EI 120 U/U	E 120 U/U
	≤ Ø 75 mm	1.9 mm	A + M	3	EI 120 U/U	E 120 U/U
	≤ Ø 75 mm	6.9 mm	A + M	3	EI 120 U/U	E 120 U/U
	≤ Ø 75 mm	1.9 – 6.9 mm	A + M	3	EI 120 U/U	E 120 U/U
	≤ Ø 110 mm	2.7 mm	A	4	EI 120 U/C	E 120 U/C
	≤ Ø 110 mm	10.0 mm	A	4	EI 120 U/C	E 120 U/C
	≤ Ø 110 mm	2.7 – 10.0 mm	A	4	EI 120 U/C	E 120 U/C

Geberit Silent PP pipes in accordance with Z-42.1-432

Supporting construction	Outer-Ø	t _{pipe}	Sealant*	No. of layers	Classifications	
Flexible and rigid walls	Ø 50 mm	2.0 mm	A + M	2	EI 120 U/U	E 120 U/U
	Ø 75 mm	2.4 mm	A + M	3	EI 120 U/U	E 120 U/U
	Ø 110 mm	3.4 mm	A	4	EI 120 U/C	E 120 U/C

Geberit Silent Pro pipes in accordance with Z-42.1-542

Supporting construction	Outer-Ø	t _{pipe}	Sealant*	No. of layers	Classifications	
Flexible and rigid walls	Ø 50 mm	2.7 mm	A + M	2	EI 120 U/U	E 120 U/U
	Ø 75 mm	3.5 mm	A + M	3	EI 120 U/U	E 120 U/U
	Ø 110 mm	4.2 mm	A	4	EI 120 U/C	E 120 U/C

Georg Fischer Silenta Premium pipes in accordance with Z-42.1-537

Supporting construction	Outer-Ø	t _{pipe}	Sealant*	No. of layers	Classifications	
Flexible and rigid walls	≤ Ø 50 mm	4.0 mm	A + M	2	EI 120 U/U	E 120 U/U
	≤ Ø 75 mm	4.5 mm	A + M	3	EI 120 U/U	E 120 U/U
	≤ Ø 110 mm	4.3 mm	A	4	EI 120 U/C	E 120 U/C

Conel Drain pipes in accordance with Z-42.1-510

Supporting construction	Outer-Ø	t _{pipe}	Sealant*	No. of layers	Classifications	
Flexible and rigid walls	Ø 50 mm	1.8 mm	A + M	2	EI 120 U/U	E 120 U/U
	Ø 75 mm	1.9 mm	A + M	3	EI 120 U/U	E 120 U/U
	Ø 110 mm	2.7 mm	A + M	4	EI 90 U/U	E 90 U/U

*Explanation of sealent types see 5. Wall application – gap filling.

Service support construction in wall

Wall Application

Plastic pipes with intended use as rainwater pipe, sewage pipe (ventilated = U/U and unventilated = U/C) and gas, drinking water and heating pipe made out of the below material and dimension:

Wavin AS+ pipes in accordance with Z-42.1-569

Supporting construction	Outer-Ø	t _{pipe}	Sealant*	No. of layers	Classifications	
Flexible and rigid walls	Ø 50 mm	3.0 mm	A + M	2	EI 120 U/U	E 120 U/U
	Ø 75 mm	3.5 mm	A + M	3	EI 120 U/U	E 120 U/U
	Ø 110 mm	5.3 mm	A	4	EI 120 U/U	E 120 U/U

Wavin SiTech+ pipes in accordance with Z-42.1-539

Supporting construction	Outer-Ø	t _{pipe}	Sealant*	No. of layers	Classifications	
Flexible and rigid walls	Ø 50 mm	1.3 mm	A + M	2	EI 120 U/U	E 120 U/U
	Ø 75 mm	2.6 mm	A + M	3	EI 120 U/U	E 120 U/U
	Ø 110 mm	3.4 mm	A	4	EI 120 U/U	E 120 U/U

Poloplast POLO-KAL NG pipes in accordance with Z-42.1-241

Supporting construction	Outer-Ø	t _{pipe}	Sealant*	No. of layers	Classifications	
Flexible and rigid walls	Ø 50 mm	2.0 mm	A + M	2	EI 120 U/U	E 120 U/U
	Ø 75 mm	2.6 mm	A + M	3	EI 120 U/U	E 120 U/U
	Ø 110 mm	3.4 mm	A	4	EI 120 U/U	E 120 U/U

Poloplast POLO-KAL 3S pipes in accordance with Z-42.1-341

Supporting construction	Outer-Ø	t _{pipe}	Sealant*	No. of layers	Classifications	
Flexible and rigid walls	Ø 75 mm	2.6 mm	A + M	3	EI 120 U/U	E 120 U/U
	Ø 110 mm	3.4 mm	A	4	EI 120 U/U	E 120 U/U

REHAU RAUPIANO plus pipes in accordance with Z-42.1-223

Supporting construction	Outer-Ø	t _{pipe}	Sealant*	No. of layers	Classifications	
Flexible and rigid walls	Ø 50 mm	1.8 mm	A + M	2	EI 120 U/U	E 120 U/U
	Ø 75 mm	1.9 mm	A + M	3	EI 120 U/U	E 120 U/U
	Ø 110 mm	2.7 mm	A	4	EI 120 U/U	E 120 U/U

*Explanation of sealant types see 5. Wall application – gap filling.

8. Wall application – type of wall (Multi-Layer pipes)

Double-sided flexible wall construction type a)

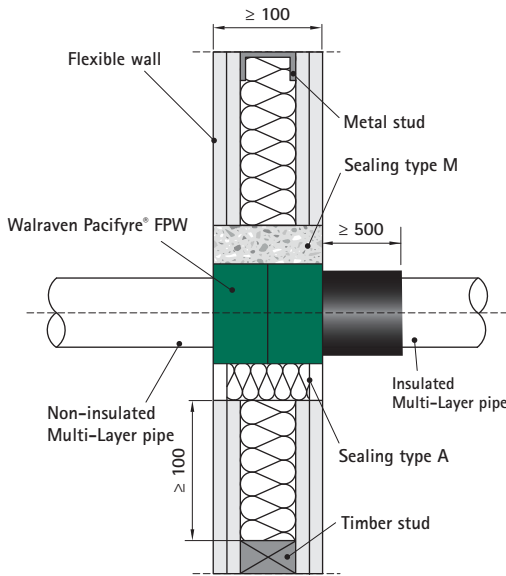

Flexible wall constructions with ≥ 2 board layers with an overall lining thickness of ≥ 25 mm (2×12.5 mm) on each side of the wall and an stone wool insulation of 50 mm with a density of ≥ 100 kg/m³.

Double-sided flexible wall construction type b)

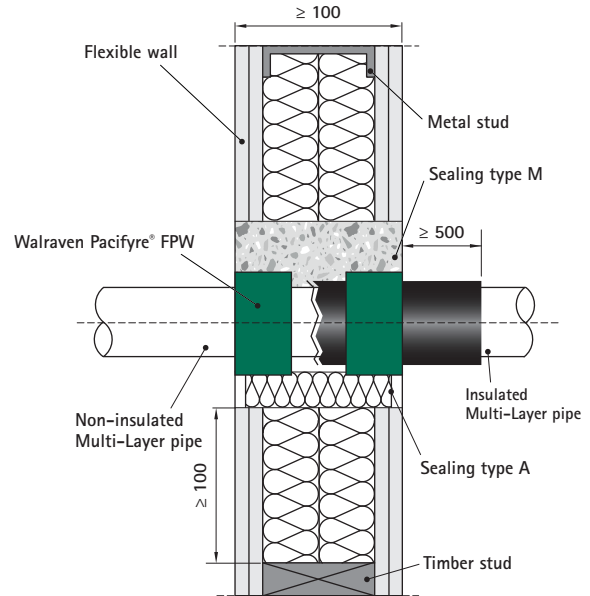

Flexible wall constructions with ≥ 2 board layers with an overall lining thickness of ≥ 25 mm (2×12.5 mm) on each side of the wall and an stone wool insulation of 2×50 mm and a density of ≥ 100 kg/m³.

Double-sided flexible wall construction type c)

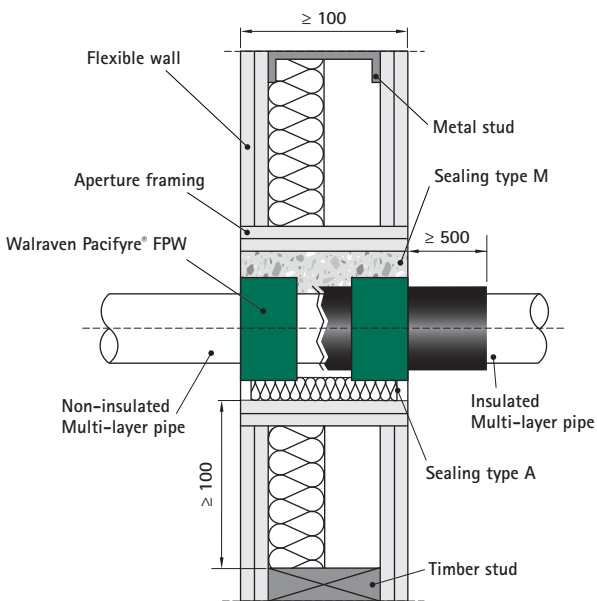

Flexible wall constructions with ≥ 2 board layers with an overall lining thickness of ≥ 25 mm (2×12.5 mm) on each side of the wall and any type of insulation.

With an aperture framing with at least 1 layer with an overall tickness of ≥ 25 mm or in case of circular apertures a dimensionally stable sleeve of materials of class A1 or A2.

Double-sided flexible wall construction type b)

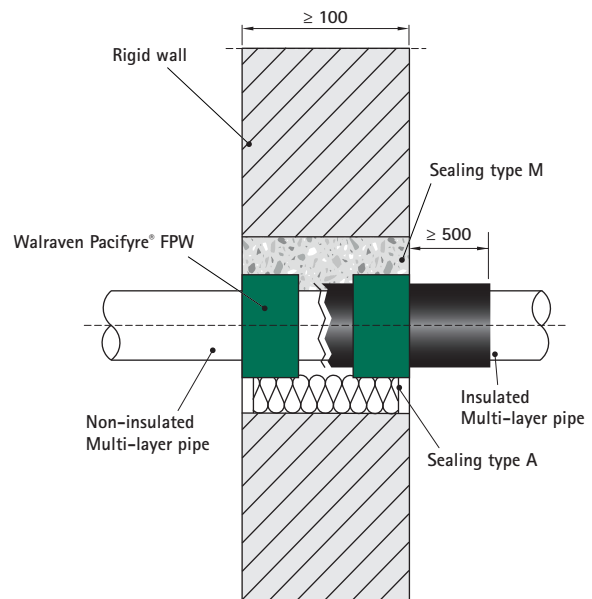

Rigid wall construction with a density of ≥ 350 kg/m³.

9. Wall application – pipe types and dimensions (Multi-Layer pipes)

Service support construction in wall

Wall Application

Multi-Layer pipes with intended use as gas, drinking water and heating pipe (insulated and non-insulated) made out of the below material and dimension:

Aquatherm green pipe SDR 9 MF RP

Supporting construction	Outer-Ø	t _{pipe}	Sealant*	No. of layers	Classifications	
Flexible and rigid walls	≤ Ø 32 mm	3.6 mm	A + M	2	EI 120 U/C	E 120 U/C
	≤ Ø 63 mm	7.1 mm	A + M	3	EI 120 U/C	E 120 U/C

Fränkische Alpex F50 PROFI or L pipes (PE-Xb / AL / PE-HD)

Supporting construction	Outer-Ø	t _{pipe}	Sealant*	No. of layers	t _{insul}	Classifications	
Flexible and rigid walls	≤ Ø 32 mm	3.0 mm	A + M	3	-	EI 120 U/C	E 120 U/C
	≤ Ø 32 mm	3.0 mm	A + M	3	27 mm	EI 120 U/C	E 120 U/C
	≤ Ø 63 mm	4.5 mm	A + M	4	-	EI 120 U/C	E 120 U/C
	≤ Ø 63 mm	4.5 mm	A + M	4	9 - 39 mm	EI 120 U/C	E 120 U/C

Uponor Unipipe MLCP pipes (PE-Xb / AL / PE-HD)

Supporting construction	Outer-Ø	t _{pipe}	Sealant*	No. of layers	t _{insul}	Classifications	
Flexible and rigid walls	≤ Ø 32 mm	3.0 mm	A + M	3	-	EI 120 U/C	E 120 U/C
	≤ Ø 32 mm	3.0 mm	A + M	3	9 - 19 mm	EI 120 U/C	E 120 U/C
	≤ Ø 50 mm	4.5 mm	A + M	3	-	EI 120 U/C	E 120 U/C
	≤ Ø 50 mm	4.5 mm	A + M	3	37.5 mm	EI 120 U/C	E 120 U/C
	≤ Ø 63 mm	6.0 mm	A + M	4	-	EI 120 U/C	E 120 U/C
	≤ Ø 63 mm	6.0 mm	A + M	4	39 mm	EI 120 U/C	E 120 U/C
	≤ Ø 110 mm	10.0 mm	A	4	-	EI 120 U/C	E 120 U/C

*Explanation of sealent types see 5. Wall application - gap filling.

Definition of possible pipe insulation installation types:

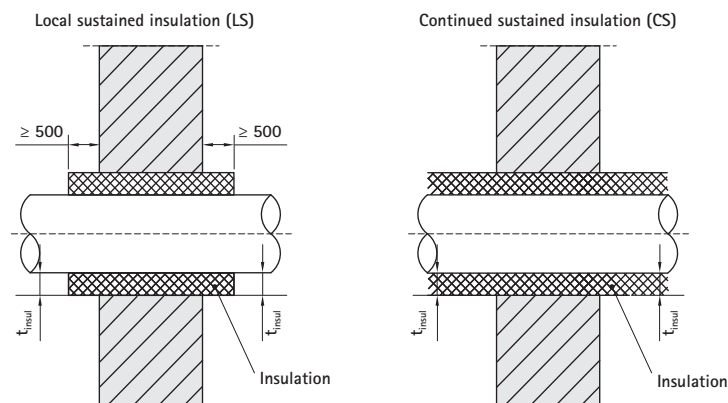

10. Floor application – Gap filling

Sealant type A | Walraven Pacifyre® A Acrylic sealant with a backfilling of firmly compressed loose wool

Floor Application

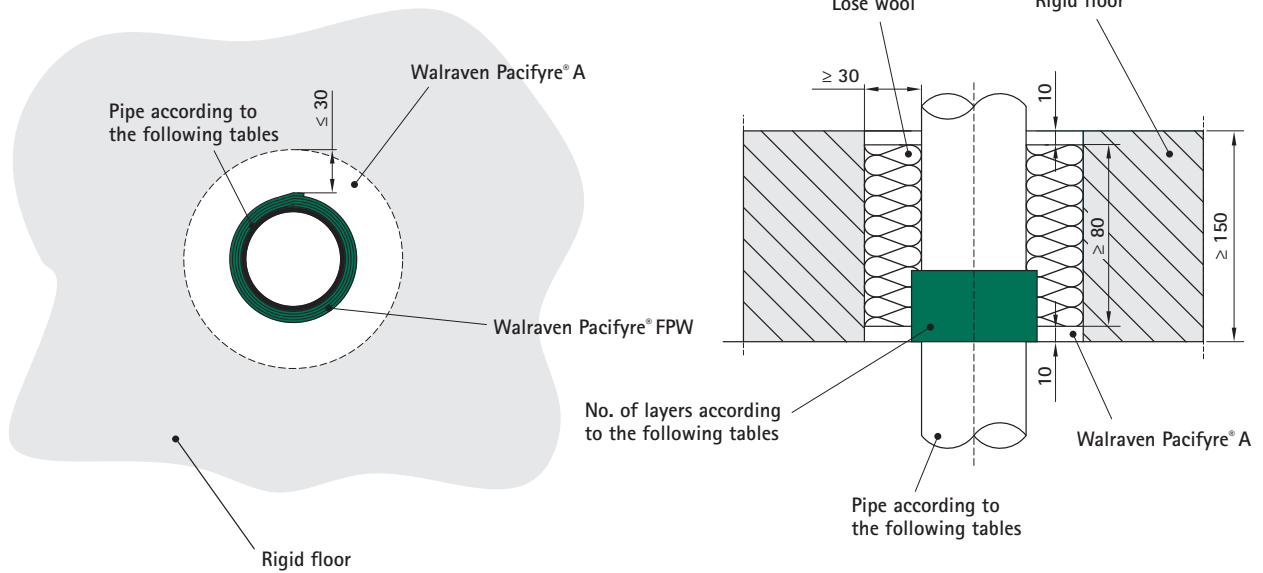

1. The backfilling is made by firmly compressed loose stone wool and fills the entire space between both layers of Walraven Pacifyre® A.

To apply the Acrylic properly the backfilling needs to be 10mm from the surface inside the floor.

2. Filling the entire aperture with Walraven Pacifyre® A between the wrap seal and the aperture edge flush with both sides of the supporting construction (floor).

Sealant type M | Walraven Pacifyre® FPM Mortar sealant

Floor Application

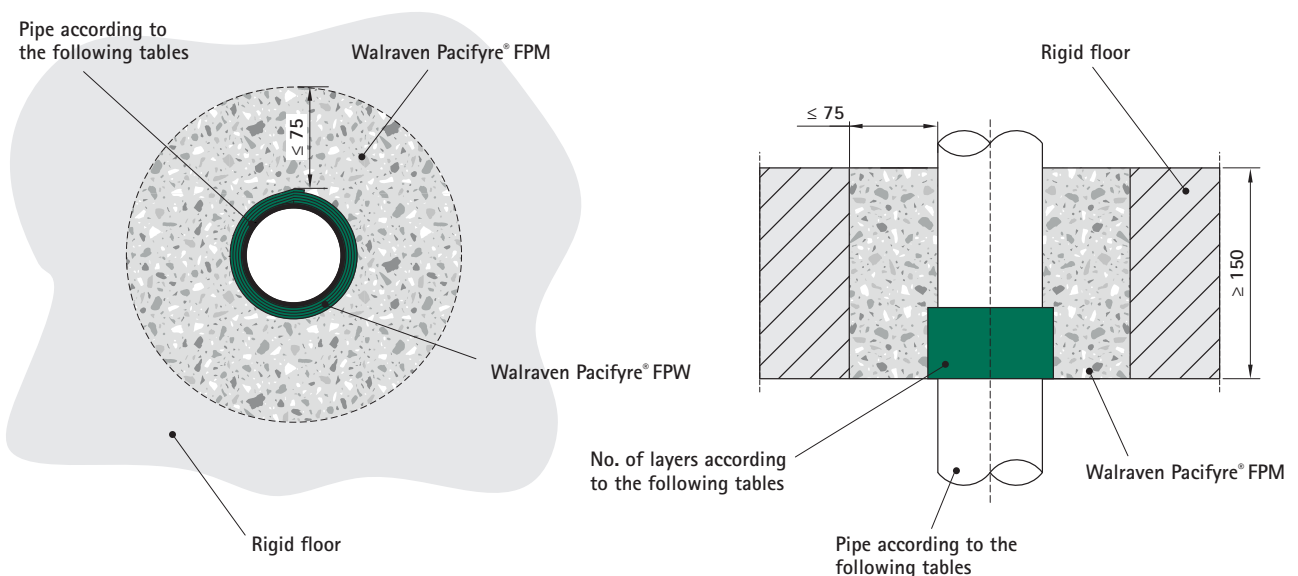

11. Floor application – pipe types and dimensions (plastic pipes)

Service support construction in floor

Floor Application

Plastic pipes with intended use as rainwater pipe, sewage pipe (ventilated = U/U and unventilated = U/C) and gas, drinking water and heating pipe made out of the below material and dimension:

Pipes made from PVC-U in accordance with EN-1329-1, EN 1453-1, EN ISO 15493 and EN ISO 1452-2 and PVC-C pipes in accordance with EN 1566-1, EN ISO 15493 and EN ISO 15877-2.

Supporting construction	Outer-Ø	t _{pipe}	Sealant*	No. of layers	Classifications	
Rigid floors	≤ Ø 50 mm	1.8 mm	A + M	2	EI 120 U/U	E 120 U/U
	≤ Ø 50 mm	5.6 mm	A + M	2	EI 120 U/U	E 120 U/U
	≤ Ø 50 mm	1.8 – 5.6 mm	A + M	2	EI 120 U/U	E 120 U/U
	≤ Ø 75 mm	1.8 mm	A + M	3	EI 120 U/U	E 120 U/U
	≤ Ø 75 mm	5.6 mm	A + M	3	EI 90 U/U	E 90 U/U
	≤ Ø 75 mm	1.8 – 5.6 mm	A + M	3	EI 90 U/U	E 90 U/U
	≤ Ø 110 mm	2.2 mm	A + M	4	EI 120 U/U	E 120 U/U
	≤ Ø 110 mm	8.2 mm	A + M	4	EI 120 U/C	E 120 U/C
	≤ Ø 110 mm	2.2 – 8.2 mm	A + M	4	EI 120 U/C	E 120 U/C
	≤ Ø 160 mm	3.2 mm	A + M	7	EI 90 U/C	E 90 U/C
	≤ Ø 160 mm	11.8 mm	A + M	7	EI 90 U/C	E 120 U/C
	≤ Ø 160 mm	3.2 – 11.8 mm	A + M	7	EI 90 U/C	E 90 U/C

Pipes made from PE in accordance with EN-1519-1, EN 12666-1, EN 12201-2 and EN ISO 15494 and PE-X pipes in accordance with EN ISO 15785-2, ABS pipes in accordance with EN 1455-1 and EN ISO 15493 as well as SAN+PVC pipes in accordance with ISO 19220.

Supporting construction	Outer-Ø	t _{pipe}	Sealant*	No. of layers	Classifications	
Rigid floors	≤ Ø 50 mm	1.8 mm	A + M	2	EI 120 U/U	E 120 U/U
	≤ Ø 50 mm	5.6 mm	A + M	2	EI 120 U/U	E 120 U/U
	≤ Ø 50 mm	1.8 – 5.6 mm	A + M	2	EI 120 U/U	E 120 U/U
	≤ Ø 75 mm	1.8 mm	A + M	3	EI 120 U/U	E 120 U/U
	≤ Ø 75 mm	8.4 mm	A + M	3	EI 120 U/U	E 120 U/U
	≤ Ø 75 mm	1.8 – 8.4 mm	A + M	3	EI 120 U/U	E 120 U/U
	≤ Ø 110 mm	2.2 mm	A + M	4	EI 120 U/U	E 120 U/U
	≤ Ø 110 mm	12.3 mm	A + M	4	EI 120 U/U	E 120 U/U
	≤ Ø 110 mm	2.2 – 12.3 mm	A + M	4	EI 120 U/U	E 120 U/U
	≤ Ø 160 mm	3.2 mm	A + M	7	EI 60 U/C	E 60 U/C
	≤ Ø 160 mm	11.8 mm	A + M	7	EI 30 U/U	E 30 U/U
	≤ Ø 160 mm	3.2 – 11.8 mm	A + M	7	EI 30 U/C	E 30 U/U

*Explanation of sealant types see 10. Floor application - gap filling.

Pipes made from PP-H in accordance with DIN 8077/78

Supporting construction	Outer-Ø	t _{pipe}	Sealant*	No. of layers	Classifications	
Rigid floors	≤ Ø 50 mm	2.0 mm	A + M	2	EI 120 U/U	E 120 U/U
	≤ Ø 50 mm	4.6 mm	A + M	2	EI 120 U/U	E 120 U/U
	≤ Ø 50 mm	2.0 – 4.6 mm	A + M	2	EI 120 U/U	E 120 U/U
	≤ Ø 75 mm	1.9 mm	A + M	3	EI 120 U/U	E 120 U/U
	≤ Ø 75 mm	6.9 mm	A + M	3	EI 120 U/U	E 120 U/U
	≤ Ø 75 mm	1.9 – 6.9 mm	A + M	3	EI 120 U/U	E 120 U/U
	≤ Ø 110 mm	2.7 mm	A	4	EI 120 U/C	E 120 U/C
	≤ Ø 110 mm	10.0 mm	A	4	EI 120 U/C	E 120 U/C
	≤ Ø 110 mm	2.7 – 10.0 mm	A	4	EI 120 U/C	E 120 U/C

Geberit Silent PP pipes in accordance with Z-42.1-432

Supporting construction	Outer-Ø	t _{pipe}	Sealant*	No. of layers	Classifications	
Rigid floors	Ø 50 mm	2.0 mm	A + M	2	EI 120 U/U	E 120 U/U
	Ø 75 mm	2.4 mm	A + M	3	EI 120 U/U	E 120 U/U
	Ø 110 mm	3.4 mm	A	4	EI 120 U/U	E 120 U/U

Geberit Silent Pro pipes in accordance with Z-42.1-542

Supporting construction	Outer-Ø	t _{pipe}	Sealant*	No. of layers	Classifications	
Rigid floors	Ø 50 mm	2.7 mm	A + M	2	EI 120 U/U	E 120 U/U
	Ø 75 mm	3.5 mm	A + M	3	EI 120 U/U	E 120 U/U
	Ø 110 mm	4.2 mm	A + M	4	EI 120 U/U	E 120 U/U

Georg Fischer Silenta Premium pipes in accordance with Z-42.1-537

Supporting construction	Outer-Ø	t _{pipe}	Sealant*	No. of layers	Classifications	
Rigid floors	Ø 50 mm	4.0 mm	A + M	2	EI 120 U/U	E 120 U/U
	Ø 75 mm	4.5 mm	A + M	3	EI 120 U/U	E 120 U/U
	Ø 110 mm	4.3 mm	A + M	4	EI 120 U/U	E 120 U/U

Conel Drain pipes in accordance with Z-42.1-510

Supporting construction	Outer-Ø	t _{pipe}	Sealant*	No. of layers	Classifications	
Rigid floors	Ø 50 mm	1.8 mm	A + M	2	EI 120 U/U	E 120 U/U
	Ø 75 mm	1.9 mm	A + M	3	EI 120 U/U	E 120 U/U

Wavin AS+ pipes in accordance with Z-42.1-569

Supporting construction	Outer-Ø	t _{pipe}	Sealant*	No. of layers	Classifications	
Rigid floors	Ø 50 mm	3.0 mm	A + M	2	EI 120 U/U	E 120 U/U
	Ø 75 mm	3.5 mm	A + M	3	EI 120 U/U	E 120 U/U
	Ø 110 mm	5.3 mm	A	4	EI 120 U/U	E 120 U/U

*Explanation of sealant types see 10. Floor application - gap filling.

Wavin SiTech+ pipes in accordance with Z-42.1-539

Supporting construction	Outer-Ø	t _{pipe}	Sealant*	No. of layers	Classifications	
Rigid floors	Ø 50 mm	1.3 mm	A + M	2	EI 120 U/U	E 120 U/U
	Ø 75 mm	2.6 mm	A + M	3	EI 120 U/U	E 120 U/U
	Ø 110 mm**	3.4 mm	A	4	EI 60 U/U	E 60 U/U

**Floor thickness > 200 mm.

Poloplast POLO-KAL NG pipes in accordance with Z-42.1-241

Supporting construction	Outer-Ø	t _{pipe}	Sealant*	No. of layers	Classifications	
Rigid floors	Ø 50 mm	2.0 mm	A + M	2	EI 120 U/U	E 120 U/U
	Ø 75 mm	2.6 mm	A + M	3	EI 120 U/U	E 120 U/U

Poloplast POLO-KAL 3S pipes in accordance with Z-42.1-341

Supporting construction	Outer-Ø	t _{pipe}	Sealant*	No. of layers	Classifications	
Rigid floors	Ø 75 mm	2.6 mm	A + M	3	EI 120 U/U	E 120 U/U
	Ø 110 mm	3.4 mm	A	4	EI 120 U/U	E 120 U/U

REHAU RAUPIANO plus pipes in accordance with Z-42.1-223

Supporting construction	Outer-Ø	t _{pipe}	Sealant*	No. of layers	Classifications	
Rigid floors	Ø 50 mm	1.8 mm	A + M	2	EI 120 U/U	E 120 U/U
	Ø 75 mm	1.9 mm	A + M	3	EI 120 U/U	E 120 U/U
	Ø 110 mm	2.7 mm	A	4	EI 120 U/U	E 120 U/U

*Explanation of sealant types see 10. Floor application - gap filling.

12. Floor application – pipe types and dimensions (Multi-Layer pipes)

Service support construction in floor

Floor Application

Multi-Layer pipes with intended use as gas, drinking water and heating pipe (insulated and non-insulated) made out of the below material and dimension:

Aquatherm green pipe SDR 9 MF RP

Supporting construction	Outer-Ø	t_{pipe}	Sealant*	No. of layers	Classifications	
Rigid floors	$\leq \varnothing 32 \text{ mm}$	3.6 mm	A + M	2	EI 120 U/C	E 120 U/C
	$\leq \varnothing 63 \text{ mm}$	7.1 mm	A + M	3	EI 120 U/C	E 120 U/C
	$\leq \varnothing 110 \text{ mm}$	12.3 mm	A + M	4	EI 120 U/C	E 120 U/C

Fränkische Alpex F50 PROFI or L Pipes (PE-Xb / AL / PE-HD)

Supporting construction	Outer-Ø	t_{pipe}	Sealant*	No. of layers	t_{insul}	Classifications	
Rigid floors	$\leq \varnothing 32 \text{ mm}$	3.0 mm	A + M	3	-	EI 120 U/C	E 120 U/C
	$\leq \varnothing 32 \text{ mm}$	3.0 mm	A + M	3	9 - 27 mm	EI 120 U/C	E 120 U/C
	$\leq \varnothing 63 \text{ mm}$	4.5 mm	A + M	4	-	EI 120 U/C	E 120 U/C
	$\leq \varnothing 63 \text{ mm}$	4.5 mm	A + M	4	9 - 39 mm	EI 120 U/C	E 120 U/C

Uponor Unipipe MLCP pipes (PE-Xb / AL / PE-HD)

Supporting construction	Outer-Ø	t_{pipe}	Sealant*	No. of layers	t_{insul}	Classifications	
Rigid floors	$\leq \varnothing 32 \text{ mm}$	3.0 mm	A + M	3	-	EI 120 U/C	E 120 U/C
	$\leq \varnothing 32 \text{ mm}$	3.0 mm	A + M	3	9 - 19 mm	EI 120 U/C	E 120 U/C
	$\leq \varnothing 50 \text{ mm}$	4.5 mm	A + M	3	-	EI 120 U/C	E 120 U/C
	$\leq \varnothing 50 \text{ mm}$	4.5 mm	A + M	3	9 - 37.5 mm	EI 120 U/C	E 120 U/C
	$\leq \varnothing 63 \text{ mm}$	6.0 mm	A + M	4	-	EI 120 U/C	E 120 U/C
	$\leq \varnothing 63 \text{ mm}$	6.0 mm	A + M	4	9 - 39 mm	EI 120 U/C	E 120 U/C
	$\leq \varnothing 110 \text{ mm}$	10.0 mm	A	4	-	EI 120 U/C	E 120 U/C

Local sustained insulation (LS)

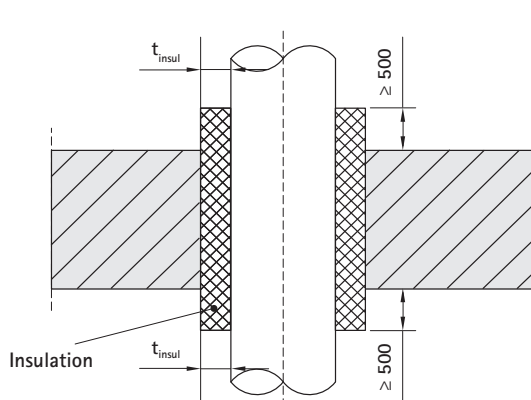

Continued sustained insulation (CS)

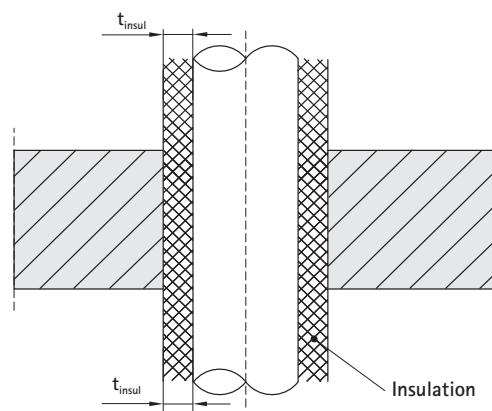

Find out how we can support you

Would you like to find out more about any of the solutions described in this Technical Data Sheet?
Or would you like to discuss how we could help you find the best possible solution for your project?
Get in touch today!

United Kingdom Ireland

Walraven Ltd.
18 Wildmere Road
Banbury (GB)
Oxon, OX16 3JU
Tel. +44 1295 75 34 00
sales.uk@walraven.com

Walraven Group

Mijdrecht (NL) · Tienen (BE) · Bayreuth (DE) · Banbury (GB) · Malmö (SE) · Grenoble (FR) · Barcelona (ES) · Milan (IT)
Kraków (PL) · Mladá Boleslav (CZ) · Kyiv (UA) · Danville (US) · Shanghai (CN) · Dubai (AE) · Budapest (HU) · Mumbai (IN)
Singapore (SG) · Burlington (CA)

Technical Data Sheet Walraven Pacifyre® FPW (EN-INT) – 10/2023 – PDF – Full content subject to modifications
* The technical data are non-binding and do not reflect the warranty characteristics of the products. They are subject to change. Please consult our General Terms and Conditions. Additional information is available upon request. It is the designer's responsibility to select products suitable for the intended purpose and to ensure that performance data are not exceeded. The installation instructions should always be read and followed.