

Walraven Strut Schuifmoer (tv)

(H 24 25)

bevestiging aan Strut-rail



651 8 0XX

651 8 1XX

651 8 2XX

Voordelen en kenmerken

- materiaal: schuifmoer van staal 1.0332; ■ thermisch verzinkt
- veer van verenstaal DIN17223 (klasse A)
- getest op brandveiligheid

Art.nr.	G	L	s (mm)	T _(inst.) (Nm)	Voor rail	F _{a,z} (N)	F _{a,x} (N)	VPE 1	VPE 2
6518006	M6	-	5,0	7,0	Strut	2.660	950	100	600
6518008	M8	-	6,0	25,0	Strut	4.500	2.200	100	600
6518010	M10	-	8,0	40,0	Strut	5.000	2.550	100	600
6518106	M6	13 mm	5,0	7,0	Strut 41x21	2.660	950	100	600
6518108	M8	13 mm	6,0	25,0	Strut 41x21	4.500	2.200	100	600
6518110	M10	13 mm	8,0	40,0	Strut 41x21	5.000	2.550	100	600
6518206	M6	33 mm	5,0	7,0	Strut 41x41	2.660	950	100	600
6518208	M8	33 mm	6,0	25,0	Strut 41x41	4.500	2.200	100	600
6518210	M10	33 mm	8,0	40,0	Strut 41x41	5.000	2.550	100	600

Vanaf M10 getest op brandveiligheid.

Geteste waarden in combinatie met BIS RapidStrut® Rail 41x41x2,5mm.

Meer informatie kan gevonden worden in de Technische Datasheet.

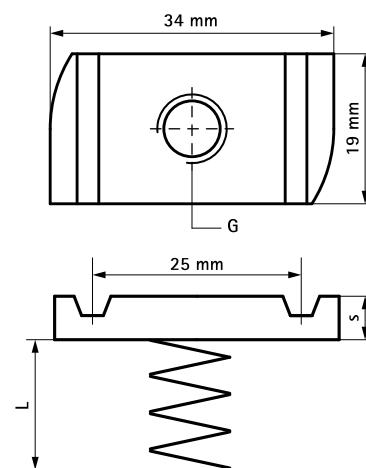

Complementair

Walraven RapidStrut® Cantilever Arm
(BUP1000)

Alternatief

Walraven Strut Schuifmoer (BUP1000)