

# BIS Schuifmoer 651D - WM3

*(G 30 15)*

bevestiging aan BIS Rail WM3



## Voordelen en kenmerken

- materiaal: staal
- elektrolytisch verzinkt

Art.nr.	G	Voor rail	$F_{a,z}$ (N)	VPE 1	VPE 2
6515008	M8	WM3	3.000	50	250
6515010	M10	WM3	3.000	50	250

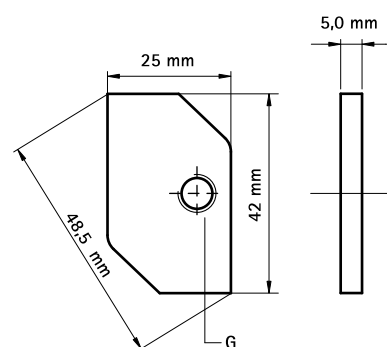

## Complementair

BIS Montagerail - WM3  
BIS Wandconsole - WM3 (BUP1000)