

WTB7 Throughbolt Anchor

(L 03 45)

high performance expansion anchor for non-cracked concrete



Prednosti i osobine

- high load capacity
- pre- and through-fixing
- two embedment depths provide installation flexibility
- materijal: čelik
- ETA Option 7 approval for non-cracked concrete
- elektrizom cinkovan
- substrate type:
 - non-cracked concrete
 - stone



Art.br.	Kode	Size	L	d ₀	h ₀	h _{min}	h _{nom}	t _{fix,max}	Rec. Load C20/25 Uncracked Concrete (kN)	KK
				(mm)	(mm)	(mm)	(mm)	(mm)		
609837080	WTB7 8x75	M8	75 mm	8	55	100	55	10	4,76*	100
609837081	WTB7 8x95	M8	95 mm	8	55	100	55	30	4,76*	100
609837082	WTB7 8x115	M8	115 mm	8	55	100	55	50	4,76*	100
609837100	WTB7 10x95	M10	95 mm	10	59	100	59	25	4,76*	50
609837101	WTB7 10x115	M10	115 mm	10	59	100	59	45	4,76*	50
609837102	WTB7 10x130	M10	130 mm	10	59	100	59	60	4,76*	50
609837120	WTB7 12x100	M12	100 mm	12	80	136	80	5	9,92*	50
609837121	WTB7 12x120	M12	120 mm	12	80	136	80	25	9,92*	50
609837122	WTB7 12x150	M12	150 mm	12	80	136	80	55	9,92*	50
609837123	WTB7 12x180	M12	180 mm	12	80	136	80	85	9,92*	50
609837160	WTB7 16x150	M16	150 mm	16	100	170	100	30	15,71*	25

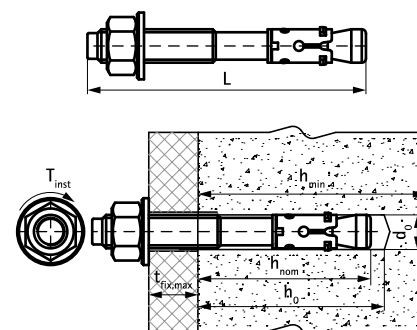

* Recommended loads: are stated for single anchors; apply to anchors correctly installed at maximum embedment depth; include partial safety factor and an overall partial safety factor for action of 1.4.

The partial safety factor for action depends on the type of loading and shall be taken from national regulations. All anchor failure modes and the entire relevant product European Technical Assessment must be considered for anchor design.

For more information, please refer to the ETA report.

Kompetabilno

- WIS Brush
- WIS Blow Pump
- WDI1 SD Stop Drill Bit

Kompetabilno

- WSDS+ Drill with 3 Cutting Edges