

BIS RapidRail® Beam Clamp

fixing to steel beam

(G 40 05)

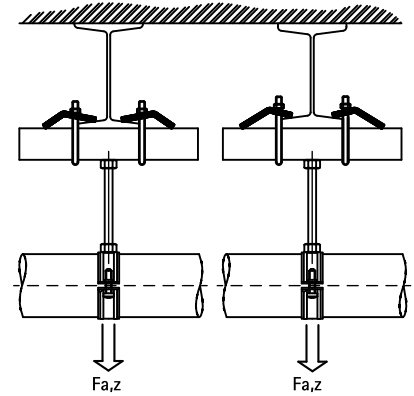

Features and benefits

- for a solid fixing to steel beams and columns without welding or drilling
- always use 2 beam clamps per fixing
- material: steel
- conforms to MFMA Metal Framing Standards (Metal Framing Manufacturers Association)
- zinc plated

Part No.	T (max.) (ft lbs)	For Rail	Fa,z (lbs)	Pack 1
658 5 011	11	WM15	1,012	50
<i>Note! Safe load (F_{a,z}) is only per set of beamclamps, per loading situation the max. allowed load of the rail must be calculated.</i>				

