

## Walraven RapidStrut® Channel (pg)

(H 04 10)

for medium weight fixing applications

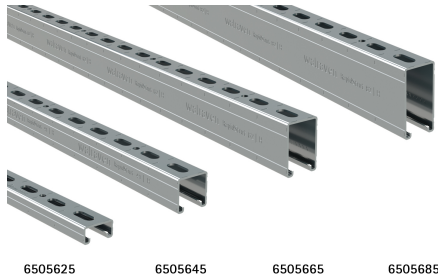

### Features and benefits

- universal rail system
- distance between rail end and first hole is always equal
- inward formed flanges with serrated profile for extra grip
- with continuous smart hole pattern including round anchor holes
- with sawing marks each 50 mm on all 3 sides of the profile
- pre-galvanized
- for more information about the max. allowed load ( $F_{a,2}$ ) please refer to the loading tables or our online datasheet 'Walraven RapidStrut® Data Sheet'
- material: steel 1.0242 (S250GD)
- Walraven RapidStrut® 41|H and 62|H tested for fire safety according to EN 1363-1
- Walraven RapidStrut® channel support systems (type 21|L, 21|H, 41|L, 41|H) conform to BS 6946:1988, the British Standard Specification for metal channel cable support systems for electrical installations

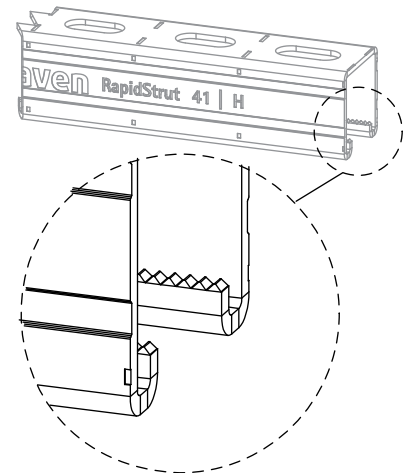

RAL-GZ 655/C  
Cert.Nr. 2012-04

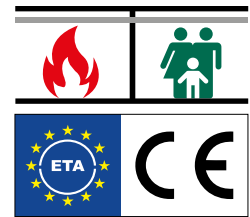

Part No.	Type	L	B	H	s	S	RAL	BndS	BndL	App.
		(mm)	(mm)	(mm)	(mm)	(mm)				
6505224	21   L	2 m	41	21	1.50	22	RAL <sup>1</sup>	20	200	m.
6505324	21   L	3 m	41	21	1.50	22	RAL <sup>1</sup>	30	300	m.
6505624	21   L	6 m	41	21	1.50	22	RAL <sup>1</sup>	60	600	m.
6505225	21   H	2 m	41	21	2.50	22	RAL <sup>1</sup>	20	200	m.
6505325	21   H	3 m	41	21	2.50	22	RAL <sup>1</sup>	30	300	m.
6505625	21   H	6 m	41	21	2.50	22	RAL <sup>1</sup>	60	600	m.
6505244	41   L	2 m	41	41	1.50	22	RAL <sup>1</sup>	20	100	m.
6505344	41   L	3 m	41	41	1.50	22	RAL <sup>1</sup>	30	150	m.
6505644	41   L	6 m	41	41	1.50	22	RAL <sup>1</sup>	60	300	m.
6505242	41   M	2 m	41	41	2.00	22	RAL <sup>1</sup>	20	100	m.
6505342	41   M	3 m	41	41	2.00	22	RAL <sup>1</sup>	30	150	m.
6505245	41   H	2 m	41	41	2.50	22	RAL <sup>1</sup>	20	100	m.
6505345	41   H	3 m	41	41	2.50	22	RAL <sup>1</sup>	30	150	m.
6505645	41   H	6 m	41	41	2.50	22	RAL <sup>1</sup>	60	300	m.
6505365	62   H	3 m	41	62	2.50	22	-	30	90	m.
6505665	62   H	6 m	41	62	2.50	22	-	60	180	m.
6505385	82   H	3 m	41	82	2.50	22	-	30	90	m.
6505685	82   H	6 m	41	82	2.50	22	-	60	180	m.
6505620	21   H	6 m	41	21	2.50	22	-	60	600	m. *
6505640	41   H	6 m	41	41	2.50	22	-	60	300	m. *

RAL<sup>1</sup> = tested, certified and monitored by a third party according to RAL-GZ 655/C.

Walraven RapidStrut® 41|H and 62|H tested for fire safety according to EN 1363-1.

\* Unslotted

For detailed technical information about our RAL marked products, please see the RAL datasheet in our web catalogue.

For more information about the max. allowed load ( $F_{a,2}$ ) please refer to the loading tables or our online datasheet 'Walraven RapidStrut® Data Sheet'.

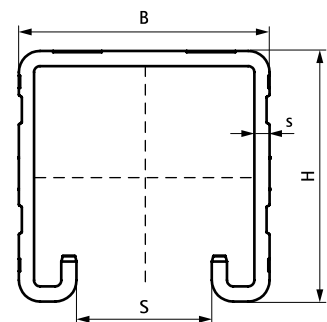

### Complementary

- Walraven RapidStrut® Hammerfix G2 (BUP1000)
- Walraven RapidStrut® Slide Nut G2 (BUP1000)

### Alternative

- Walraven RapidStrut® Channel DS 5 (BUP1000)