

# WHA1H Highload Anchor

(L 03 54)

ultimate performance anchor for cracked concrete and seismic conditions



## Features and benefits

- very high load capacity
- ETA Option 1 approval for cracked and non-cracked concrete
- fire resistance class R30-R120 for design of anchorages under exposure to fire
- seismic performance categories C1 and C2 for design of anchorages under seismic action
- material: steel
- zinc plated
- substrate type:
  - cracked concrete
  - non-cracked concrete

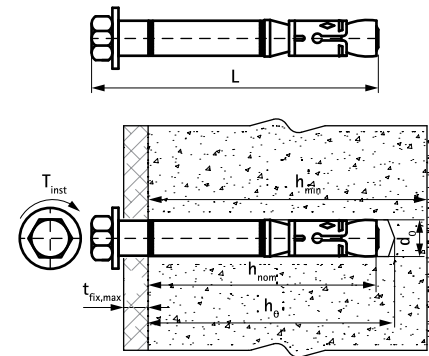

Part No.	Code	Size	L	d <sub>0</sub>	h <sub>0</sub>	h <sub>min</sub>	h <sub>nom</sub>	t <sub>fix,max</sub>	Rec. Tension Load C20/25 Uncracked Concrete (kN)	Rec. Tension Load C20/25 Cracked Concrete (kN)	Pack 1
				(mm)	(mm)	(mm)	(mm)	(mm)			
609832120	WHA1H 12x85	M8	85 mm	12	80	120	70	10	9.52*	5.71*	50
609832121	WHA1H 12x125	M8	125 mm	12	80	120	70	50	9.52*	5.71*	25
609832150	WHA1H 15x110	M10	110 mm	15	95	140	85	15	14.29*	7.62*	25
609832151	WHA1H 15x136	M10	136 mm	15	95	140	85	45	14.29	7.62*	25
609832180	WHA1H 18x117	M12	117 mm	18	105	160	95	10	17.20*	12.26*	20

\* Recommended loads: are stated for single anchors; apply to anchors correctly installed at maximum embedment depth; include partial safety factor and an overall partial safety factor for action of 1.4.  
 The partial safety factor for action depends on the type of loading and shall be taken from national regulations. All anchor failure modes and the entire relevant product European Technical Assessment must be considered for anchor design.  
 For more information, please refer to the ETA report.

### Complementary

- WIS Brush
- WIS Blow Pump
- WDI1 SD Stop Drill Bit

### Complementary

- WSDS+ 3CE Concrete Drill Bit