

WDI1 Drop-in Anchor SSt

(M 95 21)

standard stainless steel drop-in anchor



Features and benefits

- simple and quick installation procedure
- medium load capacity
- made of stainless steel for use in external atmospheric environment
- no collar for anchor setting at greater hole depth
- material: stainless steel
- ETA ETAG001 Part 6 approval for multiple use for non-structural applications
- fire resistance class R30-R120 for design of anchorages under exposure to fire (M8-M16)
- substrate type:
 - cracked concrete
 - non-cracked concrete

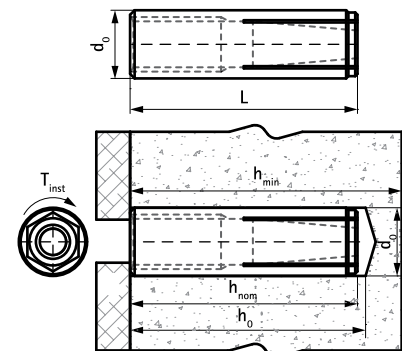

Part No.	Code	Size	L	d ₀ (mm)	h ₀ (mm)	h _{min} (mm)	h _{nom} (mm)	Rec. Tension Load C20/25 Concrete (kN)	Pack 1	Pack 2
6103708	WDI1 SSt 8x30	M8	30 mm	10	≥ 32	80	≥ 30	0.68*	100	600
6103710	WDI1 SSt 10x40	M10	40 mm	12	≥ 42	80	≥ 40	1.09*	50	500
6103712	WDI1 SSt 12x50	M12	50 mm	15	≥ 53	100	≥ 50	1.56*	50	300
6103716	WDI1 SSt 16x65	M16	65 mm	20	≥ 70	130	≥ 65	2.81*	25	200

* Recommended loads: are stated for multiple use for non-structural applications according to ETAG001, Part 6; apply to anchors correctly installed at maximum embedment depth; include partial safety factor and an overall partial safety factor for action of 1.4. The partial safety factor for action depends on the type of loading and shall be taken from national regulations. All anchor failure modes and the entire relevant product European Technical Assessment must be considered for anchor design. For more information, please refer to the ETA report.

Complementary

- WDI1 Setting Tool
- WIS Brush
- WIS Blow Pump

Complementary

- WDI1 SD Stop Drill Bit
- WSDS+ 3CE Concrete Drill Bit