

# BIS Rail WMO 'Light Duty' Set

(G 40 30)

fixing to steel beam up to flange thickness 12 mm

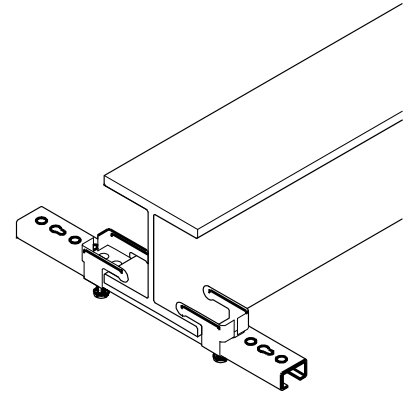
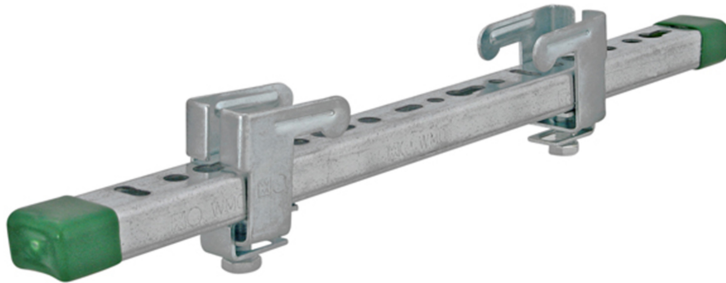

## Features and benefits

- for suspension of light components like cable trays, duct work, etc. onto beams without welding or drilling
- up to flange thickness 12 mm
- material: beam clamp made of steel; rail made of steel 1.0242
- beam clamp also available loose
- beam clamp: zinc plated; rail: pre-galvanized
- consists of:
  - 1 length of rail WMO (27x18 mm)
  - 2 Beam clamps WMO (Part No. 607 0 000)
  - 2 Rail End Caps

Part No.	A (mm)	L	T <sub>(max.)</sub> (Nm)	From rail	CSTB	Pack 1
6070300	< 12	300 mm	15.0	WMO	CSTB	20
6070400	< 12	400 mm	15.0	WMO	CSTB	20

**CSTB**

*le futur en construction*

Rapport de test n°EEM11 26035356

