

BIS RapidRail® Beam Clamp

fixing to steel beam

(G 40 05)

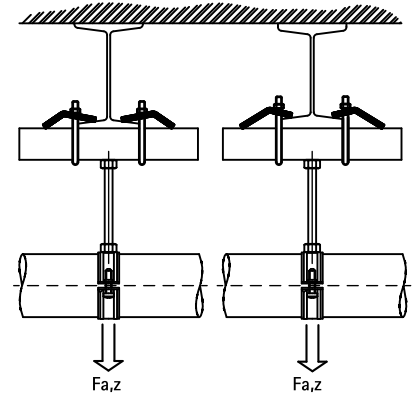

Features and benefits

- for a solid fixing to steel construction
- material: steel
- without the need for welding or drilling
- zinc plated
- always use 2 beam clamps per fixing

| Part No. | A (mm) | G | L | B (mm) | H (mm) | b (mm) | s (mm) | T _(inst.) (Nm) | For Rail | F _{a,z} (N) | Pack 1 |
|----------|-----------|----|---------|-----------|-----------|-----------|-----------|------------------------------|---|-------------------------|--------|
| 6585011 | < 16 | M6 | 45 mm | 50 | 75 | 31 | 4.0 | 15.0 | 27x18, 30x15, 30x20, 30x30, 30x45, 38x40 | 2,500 | 50 |
| 6585014 | < 20 | M8 | 60.9 mm | 80 | 100 | 44 | 4.0 | 15.0 | 38x40 | 2,500 | 50 |

Note! Safe load (F_{a,z}) is only per set of beamclamps, per loading situation the max. allowed load of the rail must be calculated.

