

BIS RapidStrut® Fixing Rail (BUP1000)

(H 04 13)

for medium weight fixing applications

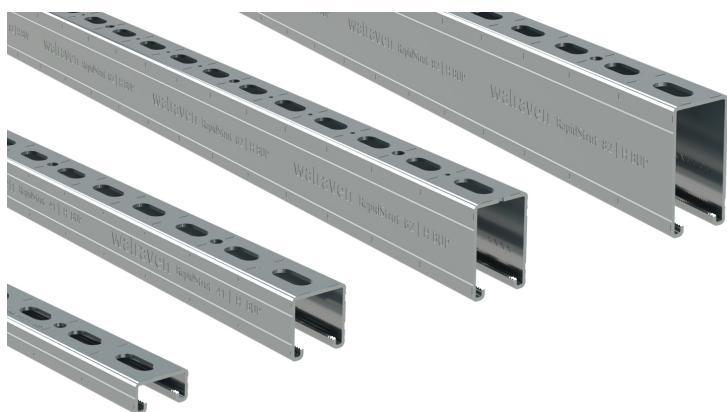

65018627

65018647

65018667

65018687

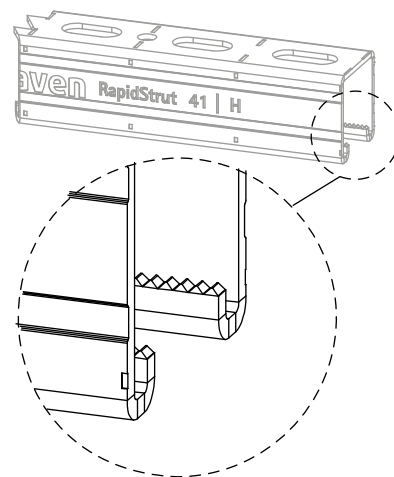

Features and benefits

- universal rail system
- corrosion protection remains intact after cutting
- distance between rail end and first hole is always equal
- with continuous smart hole pattern including round anchor holes
- with sawing marks each 50 mm on all 3 sides of the profile
- strut 41x41x2.5 and above tested for fire safety according to EN 1363-1
- inward formed flanges with serrated profile for extra grip
- material: steel 1.0242



RAL-GZ 655/C
Cert.Nr. 2015-02



Part No.	Type	L	B	H	s	S	RAL	BndS	BndL	App.
			(mm)	(mm)	(mm)	(mm)				
65018227	21 H	2 m	41	21	2.50	22	RAL ¹	20	200	m.
65018327	21 H	3 m	41	21	2.50	22	RAL ¹	30	300	m.
65018627	21 H	6 m	41	21	2.50	22	RAL ¹	60	600	m.
65018242	41 M	2 m	41	41	2.00	22	RAL ¹	20	100	m.
65018342	41 M	3 m	41	41	2.00	22	RAL ¹	30	150	m.
65018642	41 M	6 m	41	41	2.00	22	RAL ¹	60	300	m.
65018247	41 H	2 m	41	41	2.50	22	RAL ¹	20	100	m.
65018347	41 H	3 m	41	41	2.50	22	RAL ¹	30	150	m.
65018647	41 H	6 m	41	41	2.50	22	RAL ¹	60	300	m.
65018367	62 H	3 m	41	62	2.50	22	-	30	90	m.
65018667	62 H	6 m	41	62	2.50	22	-	60	180	m.
65018387	82 H	3 m	41	82	2.50	22	-	30	90	m.
65018687	82 H	6 m	41	82	2.50	22	-	60	180	m.
65018640	41 H	6 m	41	41	2.50	22	-	60	300	m. *

RAL¹ = tested, certified and monitored by a third party according to RAL-GZ 655/C. Strut 41x41x2.5 and above tested for fire safety according to EN 1363-1.

* Unslotted

For detailed technical information about our RAL marked products, please see the RAL datasheet in our web catalogue.

For more information about the max. allowed load ($F_{0,2}$) please refer to the loading tables or our online datasheet 'Technical Details BIS RapidStrut®'.

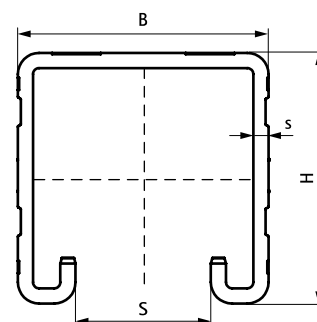

Complementary

BIS RapidStrut® Slide Nut G2 (BUP1000)
BIS RapidStrut® Hammerfix G2 (BUP1000)
BIS Yeti® 130 Support System

Complementary

BIS Yeti® 280 Support System

Alternative

BIS RapidStrut® Fixing Rail DS 5 (BUP1000)