

Walraven Yeti® Type A Rubberfoot Support System (BUP1000)

(1 04 70)

for Rooftop Installations



Features and Benefits

- for supporting small pipework systems, ductwork runs and cable trays
- to support climate installations, walkways on flat roofs, etc.
- does not penetrate the waterproof membrane (at PVC roofs a separating layer must be installed to protect against plasticizer migration - see Walraven Yeti® Triplex Separation Layer)
- material: vulcanized rubber, black; Strut Channel made of steel 1.0242
- UV resistant according to EN ISO 16474-3:2014-02 certified by ITB
- Strut Channel: surface protection:
 - product is part of the BIS UltraProtect® 1000 system
 - suitable for in- and outdoor applications
 - stands min. 1,000 hours salt spray test (max. 5% red rust) according to ISO 9227
- noise reduction according to DIN EN ISO 10140-1 and DIN EN ISO 10140-3 up to 33 dB(A)



ITB No. LZM00-2195



2058-001-24

Part No.	Model	L	B	H	F _{a,z}	Pack 1	App.
			(mm)	(mm)	(N)		
67688250	Rubberfoot incl. channel	250 mm	180	95	1,500	1	pc.
67688400	Rubberfoot incl. channel	400 mm	180	95	2,000	1	pc.
67688600	Rubberfoot incl. channel	600 mm	180	95	2,500	1	pc.
67688000	Rubberfoot incl. channel	1,000 mm	180	95	2,700	1	pc.

For a detailed calculation and for support how to spread the load please contact Walraven Technical Support.

In cases where a foot is used in roof applications, the installer is obliged to verify maximum load capacity of roof before installation.

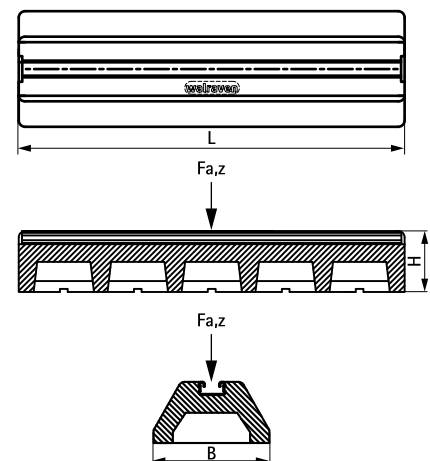

Complementary

Walraven Yeti® Triplex Separation Layer

Alternative

Walraven Yeti® Type A Rubberfoot Kits