

Walraven Yeti® Type A Rubberfoot Kits Support System (BUP1000)

(10471)

for Rooftop Installations



Features and Benefits

- assembled Kit ready to install to support small units like climate unit, heat pumps etc.
- kit contains 2 pieces of Yeti® rubberfoot Type A and 4 pieces of T-bolt assembly M8x40mm
- does not penetrate the waterproof membrane (at PVC roofs a separating layer must be installed to protect against plasticizer migration - see Walraven Yeti® Triplex Separation Layer)
- material: vulcanized rubber, black; Strut Channel made of steel 1.0242
- UV resistant
- Strut Channel and T-bolt assembly: surface protection:
 - product is part of the Walraven BIS UltraProtect® 1000 system
 - suitable for in- and outdoor applications
 - stands min. 1,000 hours salt spray test (max. 5% red rust) according to ISO 9227
 - noise reduction according to DIN EN ISO 10140-1 and DIN EN ISO 10140-3 up to 33 dB(A)



ITB No. LZM00-2195



2058-001-24

Part No.	Model	L	B	H	F _{a,z}	Pack 1	App.
			(mm)	(mm)	(N)		
67688401	Rubberfoot Kit incl. T-bolts	400 mm	180	95	2,000*	1	pc.
67688601	Rubberfoot Kit incl. T-bolts	600 mm	180	95	2,500*	1	pc.
67688001	Rubberfoot Kit incl. T-bolts	1,000 mm	180	95	2,700*	1	pc.

For a detailed calculation and for support how to spread the load please contact Walraven Technical Support.

In cases where a foot is used in roof applications, the installer is obliged to verify maximum load capacity of roof before installation.

*F_{a,z} = max. allowed load per 1 foot

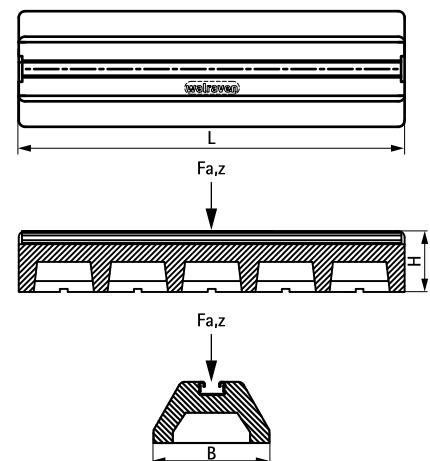

Complementary

Walraven Yeti® Triplex Separation Layer