

Walraven RapidStrut® Hammerfix G2 (BUP1000)

(H 24 49)

fixing to Strut rail



Features and Benefits

- slide nut with stud bolt, washer and BIS RapidStrut® spring
- ready-to-use pre-assembled for a quick fixing, and retains assembly in place before final tightening
- material: metal parts made of steel 1.0332; spring(s) made of POM (polyoxymethylene), green
- surface protection:
 - product is part of the Walraven BIS UltraProtect® 1000 system
 - suitable for in- and outdoor applications
 - stands min. 1,000 hours salt spray test (max. 5% red rust) according to ISO 9227



Part No.	G	L	LU (mm)	s (mm)	SW1 (mm)	T _(inst.) (Nm)	F _{a,z} (N)	F _{a,x} (N)	Pack 1	Pack 2
652785804	M8	40 mm	16	6.0	13	11.0	3,120	1,100	15	150
652785805	M8	50 mm	26	6.0	13	11.0	3,120	1,100	15	150
652785806	M8	60 mm	36	6.0	13	11.0	3,120	1,100	5	100
652785808	M8	80 mm	56	6.0	13	11.0	3,120	1,100	5	100
652785810	M8	100 mm	76	6.0	13	11.0	3,120	1,100	5	100
652785004	M10	40 mm	12	8.0	17	15.0	5,000	1,250	15	150
652785006	M10	60 mm	32	8.0	17	15.0	5,000	1,250	5	100
652785008	M10	80 mm	52	8.0	17	15.0	5,000	1,250	5	100
652785010	M10	100 mm	72	8.0	17	15.0	5,000	1,250	5	100
652785204	M12	40 mm	10	9.0	19	22.0	5,000	2,440	5	100
652785206	M12	60 mm	30	9.0	19	22.0	5,000	2,440	5	100

M10 tested for fire safety according to EN 1366-1.
 M12 tested for fire safety according to EN 1366-1.
 Tested values in combination with BIS RapidStrut® Rail 41x41x2.5mm.

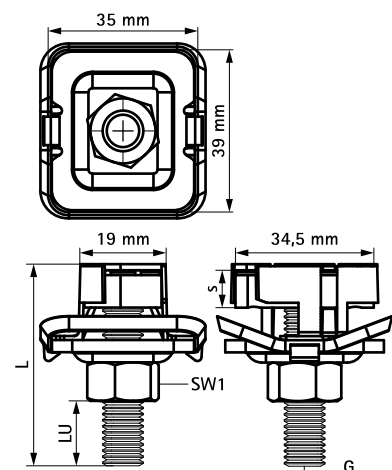

Complementary

Walraven RapidStrut® Fixing Rail DS 5 (BUP1000)
 Walraven RapidStrut® Cantilever Arm (BUP1000)