

Walraven RapidStrut® Channel DS 5 (BUP1000)

(H 04 05)

for medium weight fixing applications



Features and Benefits

- for a quick and easy fixing
- unique hole pattern, allowing BIS RapidStrut® Accessories to be mounted on both sides of the rail
- very high corrosion resistance (Walraven BIS UltraProtect® 1000)
- corrosion protection remains intact after cutting
- strength minimal equal to Strut 41x41x2.5 mm
- with continuous perforation
- distance between rail end and first hole is always equal
- a continuous graduated centimetre scale on one side
- inward formed flanges with serrated profile for extra grip
- material: steel 1.0242
- surface protection:
 - product is part of the Walraven BIS UltraProtect® 1000 system
 - suitable for in- and outdoor applications
 - stands min. 1,000 hours salt spray test (max. 5% red rust) according to ISO 9227
- for more information about the max. allowed load ($F_{a,z}$) please refer to the loading tables or our online datasheet 'Walraven RapidStrut® Data Sheet'



Part No.	L	B	H	s	S	BndS	BndL	App.
		(mm)	(mm)	(mm)	(mm)			
65058252	2 m	41	51	2.0	22	20	80	m.
65058352	3 m	41	51	2.0	22	30	120	m.
65058652	6 m	41	51	2.0	22	60	240	m.

For more information about the max. allowed load ($F_{a,z}$) please refer to the loading tables or our online datasheet 'Walraven RapidStrut® Data Sheet'.

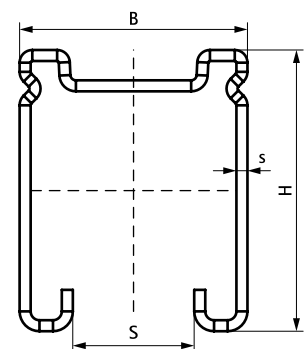

Complementary

- Walraven RapidStrut® Hammerfix G2 (BUP1000)
- Walraven RapidStrut® Rail Connector 90° G2 (BUP1000)
- Walraven RapidStrut® Rail Connector 135°

Complementary

- Walraven RapidStrut® Rail Connector G2 (BUP1000)
- Walraven RapidStrut® Rail Connector - Walraven RapidStrut® Rail