

Walraven RapidStrut® Channel (pg)

(H 04 10)

for medium weight fixing applications

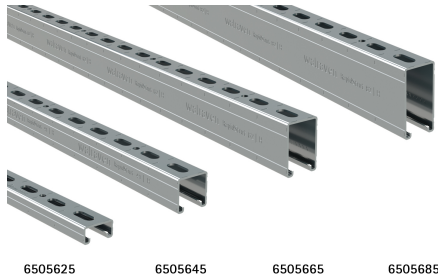

Features and Benefits

- universal rail system
- distance between rail end and first hole is always equal
- inward formed flanges with serrated profile for extra grip
- with continuous smart hole pattern including round anchor holes
- with sawing marks each 50 mm on all 3 sides of the profile
- material: steel 1.0242 (S250GD)
- pre-galvanized
- Walraven RapidStrut® 41|H and 62|H tested for fire safety according to EN 1363-1
- Walraven RapidStrut® channel support systems (type 21|L, 21|H, 41|L, 41|H) conform to BS 6946:1988, the British Standard Specification for metal channel cable support systems for electrical installations
- for more information about the max. allowed load ($F_{a,z}$) please refer to the loading tables or our online datasheet 'Walraven RapidStrut® Data Sheet'

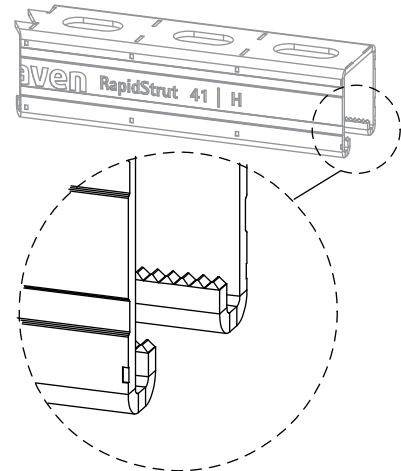

RAL-GZ 655/C
Cert.Nr. 2012-04

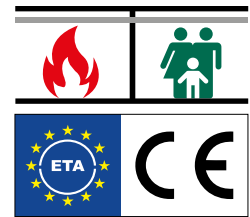

Part No.	Type	L	B	H	s	S	RAL	BndS	BndL	App.
		(mm)	(mm)	(mm)	(mm)	(mm)				
6505224	21 L	2 m	41	21	1.50	22	RAL ¹	20	200	m.
6505324	21 L	3 m	41	21	1.50	22	RAL ¹	30	300	m.
6505624	21 L	6 m	41	21	1.50	22	RAL ¹	60	600	m.
6505222	21 M	2 m	41	21	2.00	22	RAL ¹	20	200	m.
6505322	21 M	3 m	41	21	2.00	22	RAL ¹	30	300	m.
6505622	21 M	6 m	41	21	2.00	22	RAL ¹	60	600	m.
6505225	21 H	2 m	41	21	2.50	22	RAL ¹	20	200	m.
6505325	21 H	3 m	41	21	2.50	22	RAL ¹	30	300	m.
6505625	21 H	6 m	41	21	2.50	22	RAL ¹	60	600	m.
6505244	41 L	2 m	41	41	1.50	22	RAL ¹	20	100	m.
6505344	41 L	3 m	41	41	1.50	22	RAL ¹	30	150	m.
6505644	41 L	6 m	41	41	1.50	22	RAL ¹	60	300	m.
6505242	41 M	2 m	41	41	2.00	22	RAL ¹	20	100	m.
6505342	41 M	3 m	41	41	2.00	22	RAL ¹	30	150	m.
6505642	41 M	6 m	41	41	2.00	22	RAL ¹	60	300	m.
6505245	41 H	2 m	41	41	2.50	22	RAL ¹	20	100	m.
6505345	41 H	3 m	41	41	2.50	22	RAL ¹	30	150	m.
6505645	41 H	6 m	41	41	2.50	22	RAL ¹	60	300	m.
6505365	62 H	3 m	41	62	2.50	22	-	30	90	m.
6505665	62 H	6 m	41	62	2.50	22	-	60	180	m.
6505385	82 H	3 m	41	82	2.50	22	-	30	90	m.
6505685	82 H	6 m	41	82	2.50	22	-	60	180	m.
6505620	21 H	6 m	41	21	2.50	22	-	60	600	m. *
6505640	41 H	6 m	41	41	2.50	22	-	60	300	m. *

RAL¹ = tested, certified and monitored by a third party according to RAL-GZ 655/C.
Walraven RapidStrut® 41|H and 62|H tested for fire safety according to EN 1363-1.

* Unslotted

For detailed technical information about our RAL marked products, please see the RAL datasheet in our web catalogue.

For more information about the max. allowed load ($F_{a,z}$) please refer to the loading tables or our online datasheet 'Walraven RapidStrut® Data Sheet'.

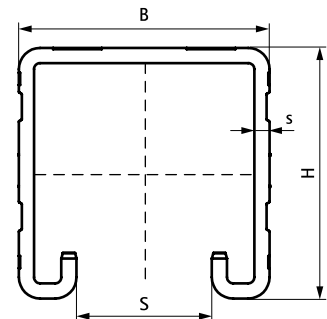

Complementary

- Walraven RapidStrut® Hammerfix G2 (BUP1000)
- Walraven RapidStrut® Slide Nut G2 (BUP1000)

Alternative

- Walraven RapidStrut® Channel DS 5 (BUP1000)