

Walraven RapidStrut® Cantilever Arm 41x41D (BUP1000)

(H 08 12)

fixing to wall, floor or ceiling

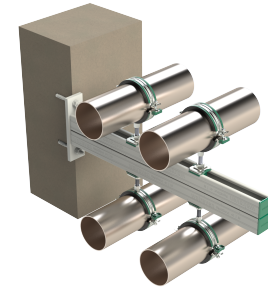

Features and Benefits

- base plate with welded C-profile
- for quick and adjustable fixing of one or multiple pipes
- CO₂ welded
- with continuous perforation
- with sawing marks each 50 mm
- well balanced relation between base plate and profile for optimal use of load performance
- material: profiles made of steel 1.0038 (S235JR)
- material: base plate made of steel 1.0044 (S275JR)
- surface protection:
 - product is part of the Walraven BIS UltraProtect® 1000 system
 - suitable for in- and outdoor applications
 - stands min. 1,000 hours salt spray test (max. 5% red rust) according to ISO 9227
- for more information about the max. allowed load ($F_{a,z}$) please refer to the loading tables or our online datasheet 'Walraven RapidStrut® Data Sheet'

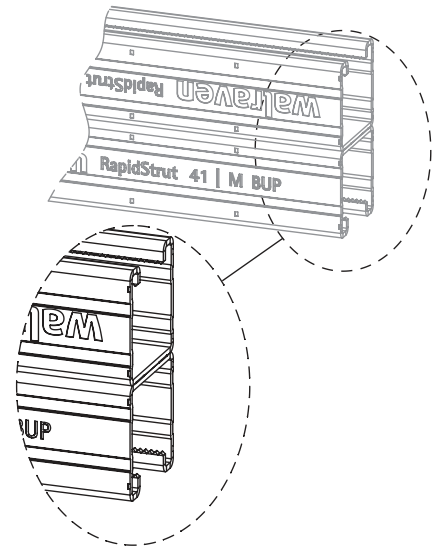

Part No.	L	B	H	s1	d1	S	k	From Rail	Pack 1	App.
		(mm)	(mm)	(mm)	(mm)	(mm)	(mm)			
66088240	400 mm	50	177.50	10.0	20 x 13	22	135	RapidStrut 41 M	8	pc.
66088260	600 mm	50	177.50	10.0	20 x 13	22	135	RapidStrut 41 M	4	pc.
66088280	800 mm	50	177.50	10.0	20 x 13	22	135	RapidStrut 41 M	-	pc.
66088298	1,000 mm	50	177.50	10.0	20 x 13	22	135	RapidStrut 41 M	-	pc.

For more information about the max. allowed load ($F_{a,z}$) please refer to the loading tables or our online datasheet 'Walraven RapidStrut® Data Sheet'.

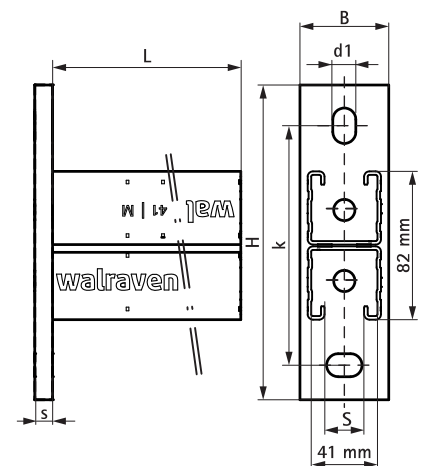

Complementary

- Walraven RapidStrut® Slide Nut G2 (BUP1000)
- Walraven RapidStrut® Hammerfix G2 (BUP1000)
- Walraven Strut Washer - L-shaped