

# Walraven RapidRail® T- and X-Connector

(G 35 45)

to make Walraven RapidRail® fabrications

A



B

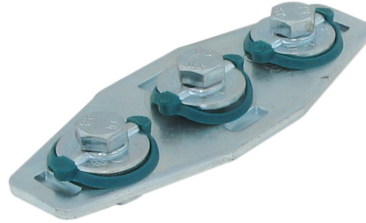

## Features and Benefits

- connector with pre-assembled BIS RapidRail® Slide nut(s)
- to make rail fabrications
- suitable for rail 27x18, 30x15, 30x20, 30x30, 30x45, 38x40
- ready-to-use pre-assembled for a quick fixing, and retains assembly in place before final tightening
- material: metal parts made of steel 1.0332; spring(s) made of POM (polyoxymethylene), green
- zinc plated

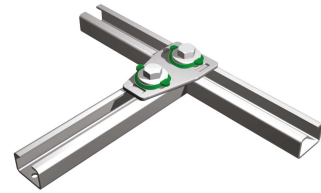

658 4 090

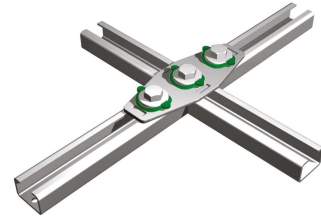

658 4 091

Part No.	Type	T <sub>(inst.)</sub> (Nm)	For Rail	F <sub>a,x</sub> (N)	RAL	Pack 1
A 6584090	T	15.0	27x18, 30x15, 30x20, 30x30, 30x45, 38x40	345	RAL <sup>1</sup>	25
B 6584091	X	15.0	27x18, 30x15, 30x20, 30x30, 30x45, 38x40	345	RAL <sup>1</sup>	25

*RAL<sup>1</sup> = tested, certified and monitored by a third party according to RAL-GZ 655/D in combination with Rail 30x15, 30x30, 30x20 and 30x45.  
For detailed technical information about our RAL marked products, please see the RAL datasheet in our web catalogue.*



RAL-GZ 655/D  
Cert.Nr. 2012-08

A

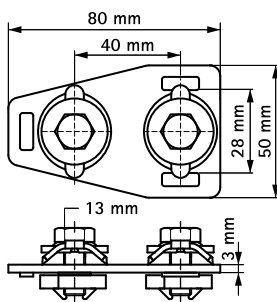

B

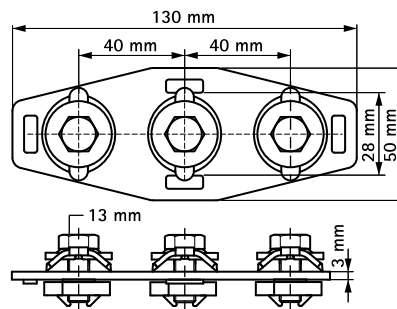

## Complementary

Walraven RapidRail® Fixing Rail