

BIS RapidStrut® Fixing Rail DS 5 (BUP1000)

(H 04 05)

for medium weight fixing applications



Features and benefits

- for a quick and easy fixing
 - unique hole pattern, allowing BIS RapidStrut® Accessories to be mounted on both sides of the rail
 - very high corrosion resistance (BIS UltraProtect® 1000)
 - corrosion protection remains intact after cutting
 - strength minimal equal to Strut 41x41x2.5 mm
 - with continuous perforation
 - distance between rail end and first hole is always equal
 - a continuous graduated centimetre scale on one side
- material: steel 1.0242

Part No.	L	B	H	s	S	BndS	BndL	App.
		(mm)	(mm)	(mm)	(mm)			
65058252	2 m	41	51	2.0	22	20	80	m.
65058352	3 m	41	51	2.0	22	30	120	m.
65058652	6 m	41	51	2.0	22	60	240	m.

For more information about the max. allowed load ($F_{a,z}$) please refer to the loading tables or our online datasheet 'Technical Details BIS RapidStrut®'.

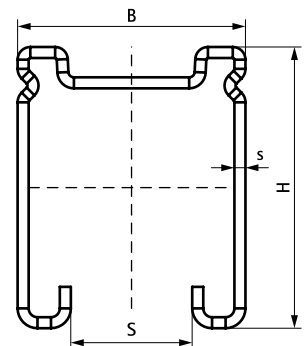

Complementary

- BIS RapidStrut® Hammerfix G2 (BUP1000)
- BIS RapidStrut® Rail Connector 90° G2 (BUP1000)
- BIS RapidStrut® Rail Connector 135° G2 (BUP1000)

Complementary

- BIS RapidStrut® Rail Connector G2 (BUP1000)
- BIS RapidStrut® Rail Connector - U-shaped G2 (BUP1000)
- BIS RapidStrut® Rail T- and X-Connector