

Walraven RapidStrut® Rail Connector 90° G2 (BUP1000)

(H 28 04)

for metal structural fabrications

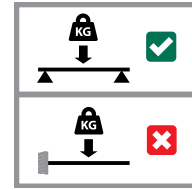

Features and benefits

- connector with pre-assembled BIS RapidStrut® Slide nut(s)
- to make fabrication with Strut Rail
- ready-to-use pre-assembled for a quick fixing, and retains assembly in place before final tightening
- 'Direct Twist' technology for easy and secure installation
- visual guide to check the position of the slide nut
- Part No. 66588520X: optimized for easy installation with electrical tools
- material: metal parts made of steel 1.0332; spring(s) made of POM (polyoxymethylene), green
- surface protection:
 - product is part of the Walraven BIS UltraProtect® 1000 system
 - suitable for in and outdoor applications
 - stands min. 1,000 hours salt spray test (max. 5% red rust) according to ISO 9227

Part No.	Thread (M)	L	L	H	H	b	b	s	k	k	a	For Rail	Pack 1
			(°)	(mm)	(°)	(mm)	(°)	(mm)	(mm)	(°)	(°)		
665885205	M10	103 mm	4	103	4	20.5	0.8	4	41	1.61	90°	Strut	20

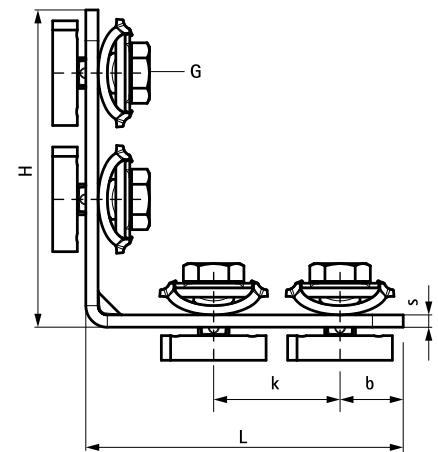

Complementary

Walraven RapidStrut® Fixing Rail DS 5
(BUP1000)