

Walraven RapidRail® T- and X-Connector

(G 35 45)

to make Walraven RapidRail® fabrications

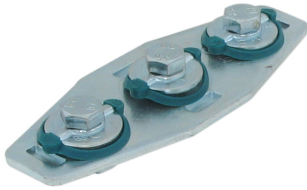

658 4 091



658 4 090

Features and benefits

- connector with pre-assembled BIS RapidRail® Slide nut
- to make rail fabrications
- suitable for rail 27x18, 30x15, 30x20, 30x30, 30x45, 38x40
- ready-to-use pre-assembled for a quick fixing, and retains assembly in place before final tightening
- conforms to MFMA Metal Framing Standards (Metal Framing Manufacturers Association)
- material: metal parts made of steel 1.0332; spring(s) made of POM (polyoxymethylene), green
- zinc plated

| Part No. | Type | T (max.) (ft lbs) | For Rail | Pack 1 |
|----------|------|----------------------|--|--------|
| 6584090 | T | 11 | 27x18, 30x15, 30x20, 30x30, 30x45, 38x40 | 25 |
| 6584091 | X | 11 | 27x18, 30x15, 30x20, 30x30, 30x45, 38x40 | 25 |

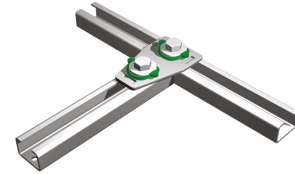

658 4 090

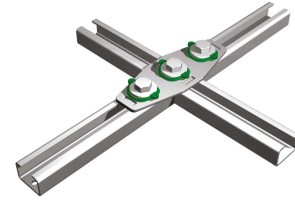

658 4 091

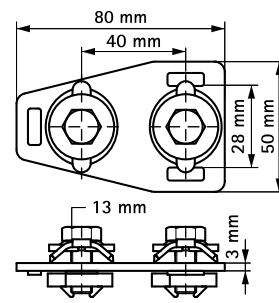

658 4 090

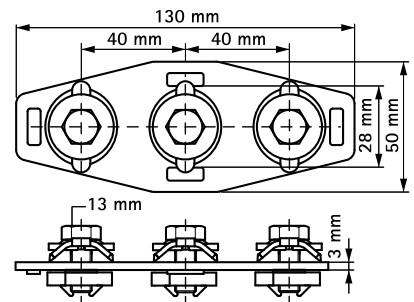

658 4 091