

# Walraven Strut Slide Nut (hdg)

(H 24 25)

fixing to Strut rail



## Features and benefits

- material: slide nut made of steel 1.0332; ■ hot dip galvanized spring made of spring steel DIN17223 (class A)
- tested for fire safety



Part No.	G	L	s (mm)	T <sub>(inst.)</sub> (Nm)	For Rail	F <sub>a,z</sub> (N)	F <sub>a,x</sub> (N)	Pack 1	Pack 2
6518006	M6	-	5.0	7.0	Strut	2,660	950	100	600
6518008	M8	-	6.0	25.0	Strut	4,500	2,200	100	600
6518010	M10	-	8.0	40.0	Strut	5,000	2,550	100	600
6518012	M12	-	9.0	50.0	Strut	5,000	2,950	100	600
6518106	M6	13 mm	5.0	7.0	Strut 41x21	2,660	950	100	600
6518108	M8	13 mm	6.0	25.0	Strut 41x21	4,500	2,200	100	600
6518110	M10	13 mm	8.0	40.0	Strut 41x21	5,000	2,550	100	600
6518112	M12	13 mm	9.0	50.0	Strut 41x21	5,000	2,950	100	600
6518206	M6	33 mm	5.0	7.0	Strut 41x41	2,660	950	100	600
6518208	M8	33 mm	6.0	25.0	Strut 41x41	4,500	2,200	100	600
6518210	M10	33 mm	8.0	40.0	Strut 41x41	5,000	2,550	100	600
6518212	M12	33 mm	9.0	50.0	Strut 41x41	5,000	2,950	100	600

M10 and above tested for fire safety.  
 Tested values in combination with BIS RapidStrut® Rail 41x41x2.5mm.  
 More details can be found on the Technical Datasheet.

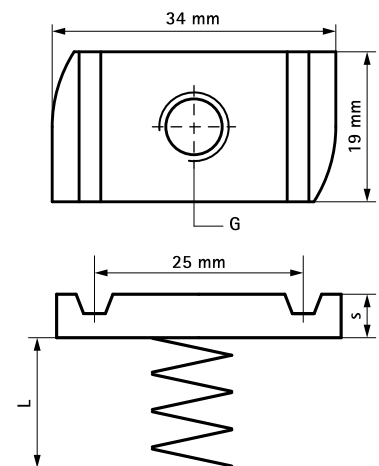

### Complementary

Walraven RapidStrut® Cantilever Arm  
(BUP1000)

### Alternative

Walraven Strut Slide Nut (BUP1000)