

# Walraven RapidStrut® Channel Double (pg)

(H 04 42)

for medium weight fixing applications

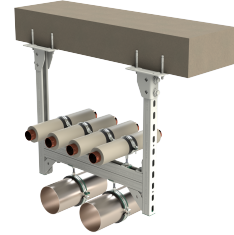

## Features and benefits

- universal rail system
- with continuous perforation
- inward formed flanges with serrated profile for extra grip
- with sawing marks each 50 mm on both sides
- material: steel 1.0242 (S250GD)
- pre-galvanized
- version 62|H Double tested for fire safety
- for more information about the max. allowed load ( $F_{a,z}$ ) please refer to the loading tables or our online datasheet 'Walraven RapidStrut® Data Sheet'

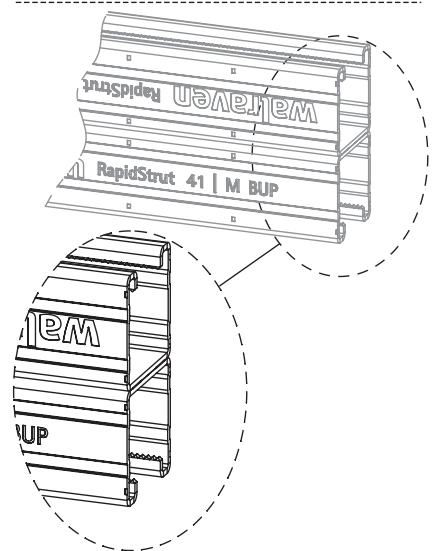

Part No.	L	B	H	s	S	Pack 1	App.
		(mm)	(mm)	(mm)	(mm)		
65015626	6 m	41	42 (21 x 2)	2,00	22	150	m.
65015646	6 m	41	82 (41 x 2)	2,00	22	150	m.
65015666	6 m	41	124 (62 x 2)	2,50	22	150	m.

*For more information about the max. allowed load ( $F_{a,z}$ ) please refer to the loading tables or our online datasheet 'Walraven RapidStrut® Data Sheet'.*



62|H Double only

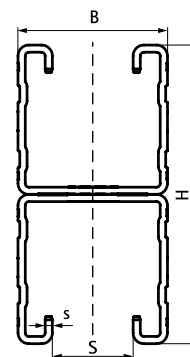

## Complementary

- Walraven RapidStrut® Slide Nut G2 (BUP1000)
- Walraven RapidStrut® Hammerfix G2 (BUP1000)
- Walraven Strut Washer - U-shaped

## Alternative

- Walraven RapidStrut® Channel Double (BUP1000)