

Walraven RapidStrut® Channel (BUP1000)

(H 04 13)

for medium weight fixing applications



65018627

65018647

65018667

65018687

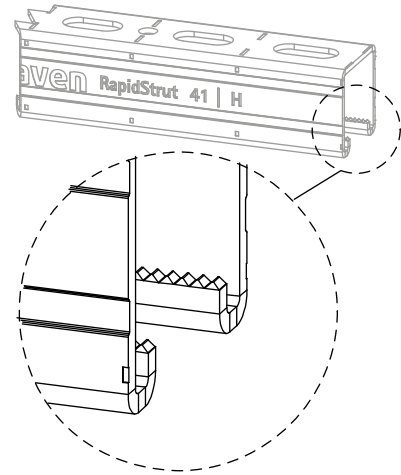

Features and benefits

- universal rail system
- corrosion protection remains intact after cutting
- distance between rail end and first hole is always equal
- inward formed flanges with serrated profile for extra grip
- with continuous smart hole pattern including round anchor holes
- with sawing marks each 50 mm on all 3 sides of the profile
- surface protection:
 - product is part of the Walraven BIS UltraProtect® 1000 system
 - suitable for in- and outdoor applications
 - stands min. 1,000 hours salt spray test (max. 5% red rust) according to ISO 9227
- Walraven RapidStrut® 41|H and 62|H tested for fire safety according to EN 1363-1
- Walraven RapidStrut® C-profil skinnesystemer (type 21| L, 21| H, 41| L, 41| H) i overensstemmelse med BS 6946: 1988, den britiske standardspecifikation for ståkanal kabelstøttesystemer til elektriske installationer
- material: steel 1.0242 (S250GD)

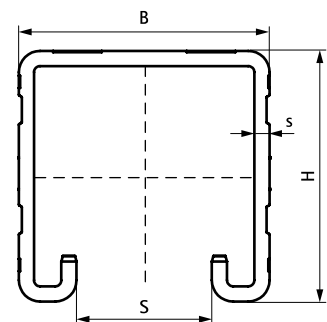
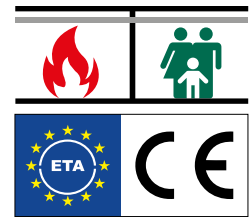

Complementary

Walraven RapidStrut® Slide Nut G2 (BUP1000)
Walraven RapidStrut® Hammerfix G2 (BUP1000)
Walraven Yeti® 130 Support System

Complementary

Walraven Yeti® 280 Support System

Alternative

Walraven RapidStrut® Channel DS 5 (BUP1000)

Walraven RapidStrut® Channel (BUP1000)

(H 04 13)

for medium weight fixing applications



65018627

65018647

65018667

65018687

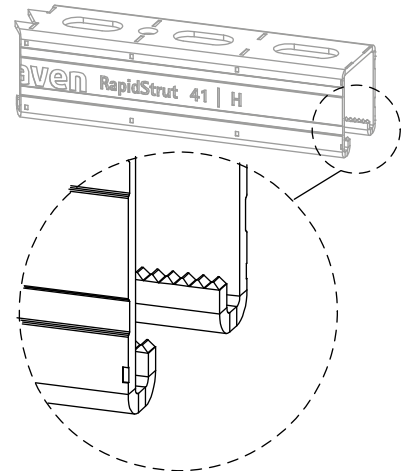

6501847100	41 H	1 m	41	41	2.50	22	RAL ¹	-	-	pc.
6501847120	41 H	1,2 m	41	41	2.50	22	RAL ¹	-	-	pc.
6501847180	41 H	1,8 m	41	41	2.50	22	RAL ¹	-	-	pc.
65018247	41 H	2 m	41	41	2.50	22	RAL ¹	20	100	m.
6501847240	41 H	2,4 m	41	41	2.50	22	RAL ¹	-	-	pc.
65018347	41 H	3 m	41	41	2.50	22	RAL ¹	30	150	m.
65018647	41 H	6 m	41	41	2.50	22	RAL ¹	60	300	m.
65018367	62 H	3 m	41	62	2.50	22	-	30	90	m.
65018667	62 H	6 m	41	62	2.50	22	-	60	180	m.
65018387	82 H	3 m	41	82	2.50	22	-	30	90	m.
65018687	82 H	6 m	41	82	2.50	22	-	60	180	m.
65018640	41 H	6 m	41	41	2.50	22	-	60	300	m.

RAL¹ = tested, certified and monitored by a third party according to RAL-GZ 655/C.
Walraven RapidStrut® 41|H and 62|H tested for fire safety according to EN 1363-1.

* Unslotted

For detailed technical information about our RAL marked products, please see the RAL datasheet in our web catalogue.

For more information about the max. allowed load ($F_{0,2}$) please refer to the loading tables or our online datasheet 'Walraven RapidStrut® Data Sheet'.



RAL-GZ 655/C
Cert.Nr. 2015-02

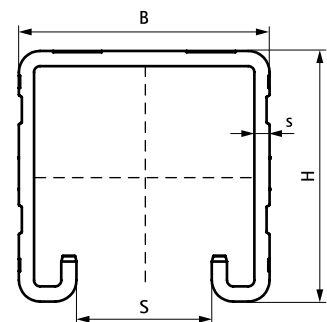
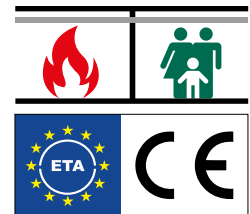

Complementary

Walraven RapidStrut® Slide Nut G2 (BUP1000)
Walraven RapidStrut® Hammerfix G2 (BUP1000)
Walraven Yeti® 130 Support System

Complementary

Walraven Yeti® 280 Support System

Alternative

Walraven RapidStrut® Channel DS 5 (BUP1000)