

# W-LX-N Concrete Screw

(L 03 59)

unibody zinc-plated concrete screw with an internal M8/M10 thread

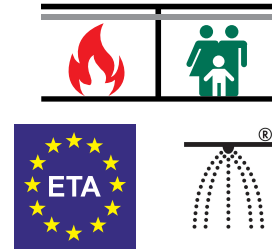
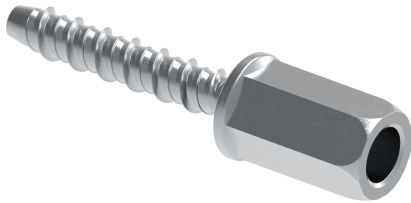

## Features and benefits

- very high load capacity
- approved for use in precast prestressed hollow core slabs
- up to 3 anchoring depths provide maximum installation flexibility
- reduced edge and anchor spacing distances
- removable
- unique tip and thread geometry prevents concrete spalling
- material: steel
- zinc plated
- fire resistance class R30-R120 for design of anchorages under exposure to fire
- complies with VdS CEA 4001:2014-04 (05) and VdS CEA 4001:2018-01 (06) for applications with sprinkler systems in concrete elements
- substrate type:
  - cracked concrete
  - non-cracked concrete
  - precast pre-stressed hollow core slabs

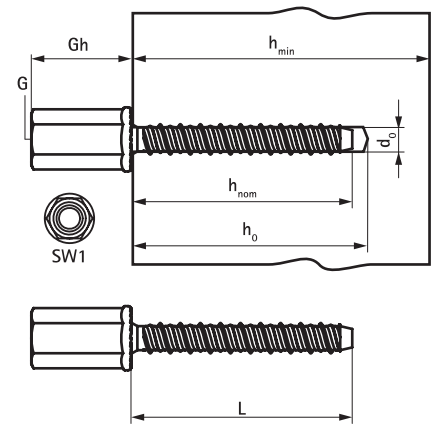

Part No.	Code	G	Gh	L	d <sub>0</sub>	h <sub>0</sub>	h <sub>min</sub>	h <sub>nom</sub>	SW1	Rec. Tension Load C20/25 Concrete (kN)	ETA	Pack 1
			(mm)		(mm)	(mm)	(mm)	(mm)	(mm)			
62433304	W-LX-N 6x35	M8/10	25	35 mm	6	45	80	35	SW13	1.42**	ETA-21/0613*	100
62433314	W-LX-N 6x35	M8	15	35 mm	6	45	80	35	SW13	1.42**	ETA-21/0613*	100
62433324	W-LX-N 6x35	M10	15	35 mm	6	45	80	35	SW13	1.42**	ETA-21/0613*	100
62433305	W-LX-N 6x55	M8/10	25	55 mm	6	45/50/65	80/80/84	35/39/55	SW13	1.42/2.85/4.28**	ETA-21/0613*	100
62433315	W-LX-N 6x55	M8	15	55 mm	6	45/50/65	80/80/84	35/39/55	SW13	1.42/2.85/4.28**	ETA-21/0613*	100
62433325	W-LX-N 6x55	M10	15	55 mm	6	45/50/65	80/80/84	35/39/55	SW13	1.42/2.85/4.28**	ETA-21/0613*	100

\*Performance and installation data is given for the specified European Technical Assessment. For full product data please refer to product data sheets. ETA-21/0612 according to EAD 330232-00-0601 anchoring in cracked and non-cracked concrete; ETA-21/0613 according to EAD 330747-00-0601 for multiple use for non-structural applications.

\*\*Recommended load includes a partial safety factor and an overall partial safety factor for action of 1.4. The partial safety factor for action depends on the type of loading and shall be taken from national regulations. All anchor failure modes and the entire relevant product European Technical Assessment must be considered for anchor design.