

Technical Information BIS RapidStrut® fire tested fixing

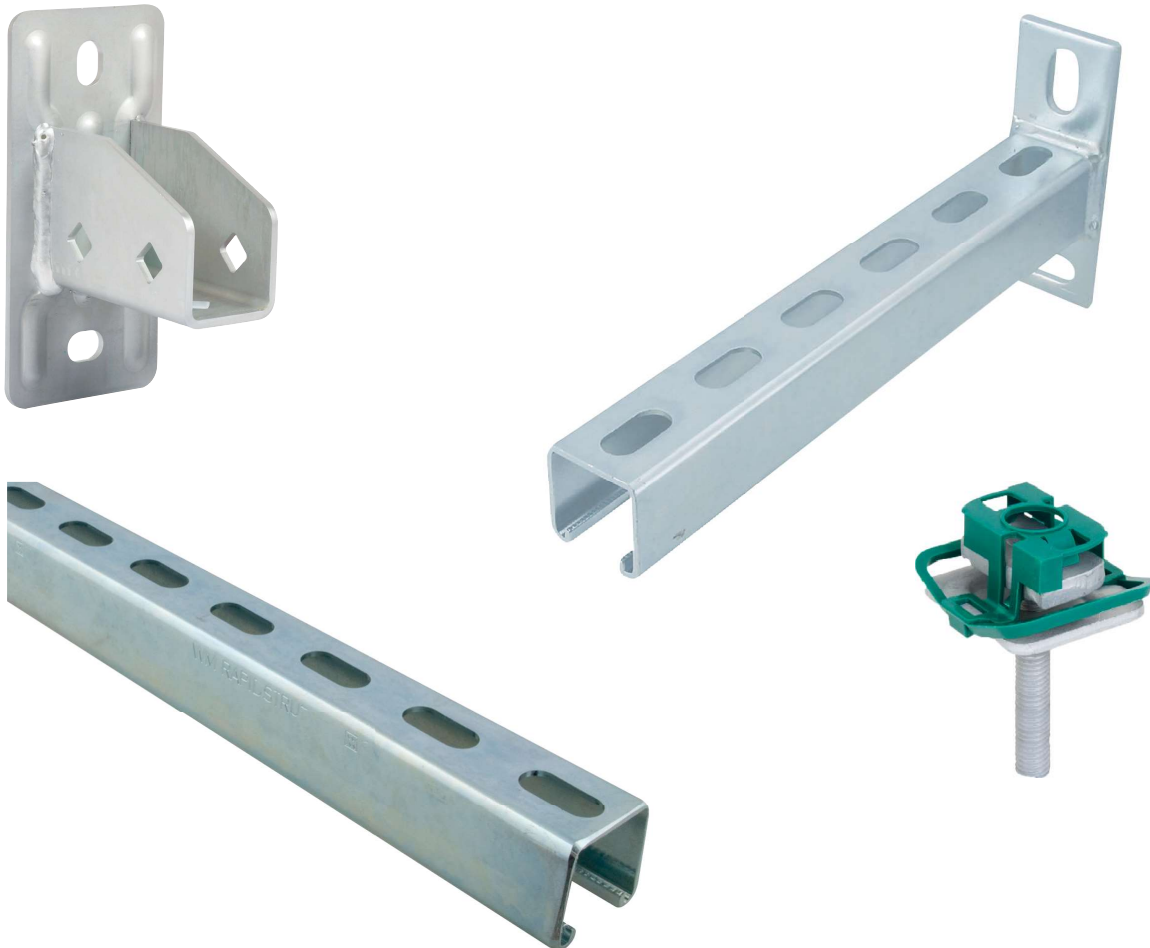

Expert Opinion 3184/198/12-CM

- Fire behaviour test to determine the fire resistance duration -

Deutschland
Österreich - Schweiz - South East Europe

Walraven GmbH
Karl-von-Linde-Str. 22
D-95447 Bayreuth
Tel. +49 (0)921 75 60 0
Fax +49 (0)921 75 60 111
info.de@walraven.com

Walraven Group

Mijdrecht (NL) • Tienen (BE) • Bayreuth (DE)
Banbury (GB) • Malmö (SE) • Grenoble (FR)
Barcelona (ES) • Kraków (PL) • Mladá
Boleslav (CZ) • Moscow (RU) • Kyiv (UA)
Detroit (US) • Shanghai (CN) • Dubai (AE)
Budapest (HU) • Mumbai (IN) • Singapore (SG)

Expert Opinion

– Translation –

Document number: (3184/198/12) – CM dated 21/11/2019

Client: J. van Walraven Holding B.V
Industrieweg 5
93641 RK Mijdrecht 5447
THE NETHERLANDS

Order date: 26/02/2019

Order ref.: Mr Geissler

Order received: 26/02/2019

Subject: Assessment of loaded BIS RapidStrut® Fixing Rails combined with threaded rods fixed to solid structural elements with regard to loadbearing capacity and deformation under exposure to fire along the standard temperature-time curve (ETK) in accordance with DIN EN 1363-1

Basis for assessment: See Section 1



This expert opinion comprises 10 pages including cover sheet and 24 annexes.

The expert opinion 3184/198/12 was prepared for the first time on 04/04/2014.

This document may only be circulated as a complete text without alterations. Excerpts or abridged versions of this document are subject to approval in writing of MPA Braunschweig. Translations of this document that are made without the approval of MPA Braunschweig must bear the note "translation of the German original not examined by MPA Braunschweig". The first sheet of this document and the page carrying the signatures bear the official stamp of MPA Braunschweig. Documents without signature and the official stamp are invalid. Expert opinion

1 General

An expert opinion on the assessment of loaded BIS RapidStrut® Fixing Rails combined with threaded rods fixed to solid structural elements with regard to loadbearing capacity and deformation under exposure to fire along the standard temperature-time curve (ETK) in accordance with DIN EN 1363-1 was commissioned in writing by J. van Walraven Holding B.V on 26/02/2019.

The documents serving as basis for the Expert Opinion on the constructions to be assessed are listed as follows:

- [1] DIN EN 1363-1 : 2012-10, Fire resistance tests – Part 1: General Requirements;
- [2] Specimen guideline on fire protection requirements pertaining to conduits (Specimen Conduit Guideline [German designation: MLAR]), edition of 10/02/2015;
- [3] Test Report No. (3075/2136)-CM, issued for J. van Walraven Holding B.V and
- [4] Technical Data Sheets for BIS RapidStrut® Fixing Rails from J. van Walraven Holding B.V.

The assessment for the BIS RapidStrut® Fixing Rails combined with threaded rods was conducted on the basis of the fire tests carried out. Existing technical regulations and technical specifications, which regulate products for the installation of electrical conduits when exposed to fire, currently provide no complete design concept for the fastening systems described in the following. According to J. van Walraven Holding B.V, there is currently no complete construction supervisory authority certificate (e.g. ETA) for BIS RapidStrut® Fixing Rails that lays down the regulations to be met by the execution described here in the event of fire.

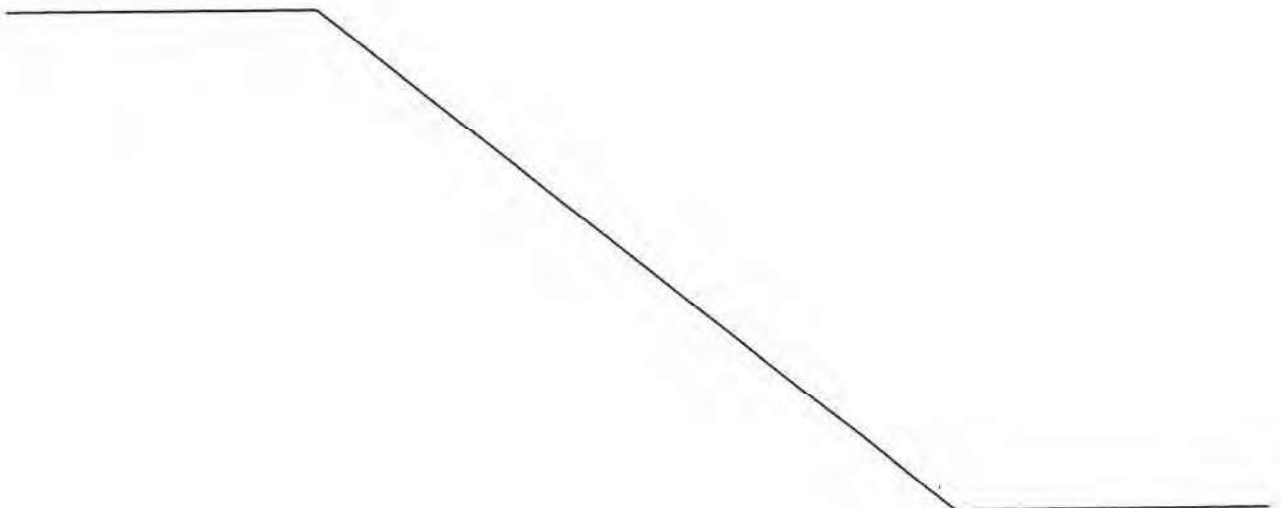

2 Description of the constructions

BIS RapidStrut® Fixing Rails are mounting systems made of galvanized steel that are used for fixing conduit systems. The loads are applied via the mounting rails and the connected threaded rods combined with suitable fasteners into the anchoring base. The fastenings in the substrate must be executed in accordance with Section 4.4.

Annexes 1 to 4 show the single constructions in detail. In addition, the individual load cases are distinguished for dimensioning (single load, uniformly distributed load, multiple load).

Threaded rods of at least the M10 size (strength ≥ 4.8 grade) must be used for the suspension system. Where multiple-span systems are installed (continuous beams), the intermediate supports in the form of threaded rod hangers must be of at least the M12 size.

Nodes between the rails and the threaded rods take the form of BIS Strut Washer U-shaped $\varnothing 11 / \varnothing 13$, positioned on both sides, in conjunction with the corresponding nuts (strength class 8). The lateral rail projection distance, measured from the central axis of the vertical fastening (threaded rod, threaded bolt), is ≥ 25 mm. Fixing to the rail is done in the existing through-hole of the mounting rail. The maximum projection of the nuts and threaded rods below the rails shall not exceed $\ddot{u} = 30$ mm. In case of larger projections ($\ddot{u}_{act} > 30$ mm) of the threaded rods, the amount of $\ddot{u}_{act} - 30$ mm is to be added to the minimum distance determined (min. a).

For elevation, the installations are fixed from above in the BIS RapidStrut® Fixing Rails using BIS Strut® Slide Nut $\geq M10$ or BIS RapidStrut® Hammerfix $\geq M10$. The suspension of installations is also possible. For this purpose, the threaded rods are laid through the through-hole and fixing is done on both sides using BIS Strut Washers U-shaped $\varnothing 11 / \varnothing 13$ and nuts.

The tables below and the annexes summarize the structural design data (manufacturer data) of the BIS RapidStrut® Fixing Rails. Further information can be taken from the technical data sheets (e.g., assembly instruction) from J. van Walraven Holding B.V.

Table 1: Product range of BIS RapidStrut® Fixing Rails

Designation	Installation	Maximum span [mm]	Clamp fitting ¹⁾
	Type of installation / suspension / connection to the rail		Combined with nuts and, if required, threaded bolts
BIS RapidStrut® 41x41x2.5 "suspended mounting" (rail back downwards)	Ceiling installation, suspended on both side and fixed in the solid substrate using anchors / threaded rods ≥ M10 (4.8), nuts and BIS Strut Washers U-shaped Ø 11 / Ø 13	800	BIS RapidStrut® Hammerfix ≥M10 and/or BIS RapidStrut® Slide Nut ≥M10 and/or
			BIS Strut® Slide Nut ≥M10 with BIS Strut Washers U-shaped and/or BIS RapidStrut® Slide Nut with Plastic Tabs ≥M10 with BIS Strut Washer U-shaped and/or
			BIS Strut Washer U-shaped Ø 11 / Ø 13
BIS RapidStrut® 41x41x2.5 "direct mounting" (rail back upwards)	Ceiling installation, fixed in solid substrate using threaded rods ≥ M10 (4.8), nuts and BIS Strut Washer U-shaped Ø 11 / Ø 13	400	BIS Strut® Slide Nut ≥M10 with BIS Strut Washer U-shaped and/or BIS RapidStrut® Slide Nut with Plastic Tabs ≥M10 with BIS Strut Washer U-shaped and/or
			BIS Strut Washer U-shaped Ø 11 / Ø 13
BIS RapidStrut® Cantilever Arm (rail back downwards)	Ceiling/wall installation, fixed in solid substrate with anchors/threaded rods ≥ M10 (4.8), nuts and BIS Strut Washer U-shaped Ø 11 / Ø 13	700	BIS RapidStrut® Hammerfix ≥M10 and/or BIS RapidStrut® Slide Nut ≥M10 and/or
BIS RapidStrut®-Base Plate / BIS Strut-Base Plate mit BIS RapidStrut® 41x41x2,5 (rail back downwards)			BIS Strut® Slide Nut ≥M10 with BIS Strut washer U-shaped and/or BIS RapidStrut® Slide Nut with Plastic Tabs ≥M10 with BIS Strut U- shaped and/or
			BIS Strut Washer U-shaped Ø 11 / Ø 13

1) The execution depends on the individual fixing system and the arrangement of the conduit.

3 Assessment of the construction

This fire-safety assessment was made for BIS RapidStrut® Fixing Rails combined with threaded rods that are fixed in solid structural elements with regard to the loadbearing capacity and deformation under exposure to fire along the standard temperature-time curve (ETK) in accordance with DIN EN 1363-1.

This fire-safety assessment is restricted to mainly static (non-moving) loads combined with solid structural elements that must be classified in at least the same fire resistance class as the fixing systems.

The fire-safety-related design with regard to buckling of the mounted installations (elevation, threaded rod) due to the fire load is not the subject of this assessment.

When connecting system components to solid walls it has to be ensured that these are able to absorb the tensile and compressive forces occurring in the event of fire.

For the systems assessed, single loads are taken up centrally and multiple loads are distributed and taken up uniformly over the mounting rail system. Where this is not feasible, the loads must be adapted so that the maximum permissible steel stresses in the threaded rods are not exceeded. The maximum permissible steel stresses for the individual load case are calculated from the normal forces acting on the threaded rods of the suspension system (see also $N_{\text{fire}(t)}$ according to Section 3), relative to the calculated core cross section of the M10 threaded rods ($A_s = 58 \text{ mm}^2$).

The stated loads for single loads or multiple loads (arranged adjacently) are summated values for the maximum total loads per fastening point on the rail. This means that the stated load, with simultaneous elevation and suspension at one point on the rail must not be exceeded by the total load.

Requirements to be fulfilled by fastenings and mounting systems (e.g., pipe clamps, mounting rails, pendulum suspensions, ...) with regard to the loadbearing capacity $N_{\text{fire}(t)}$ and the deformation $f_{(t)}$ are imposed in conjunction with conduits (see, for example, Specimen Guideline on fire protection requirements pertaining to conduits (Specimen Conduit Guideline [German designation: MLAR]), edition of 10/02/2015, Sections 2.1 and 3.5). According to MLAR, the fastening is part of the conduit system; special requirements may result in conjunction with ceilings (MLAR, Section 3.5). In conjunction with penetration seals, too, requirements to be fulfilled by the fastening of conduits may result from the general technical approval.

The individually required minimum distance $\min. a$ can be determined on the basis of the deformations stated in the annexes. The deformations stated in the following only refer to the mounting rails

combined with threaded rods under exposure to fire. Additional deformations due to the conduit systems (e.g., the deformation of a pipe) must be taken into account separately.

Figure 1: Example of a mounting rail in the ceiling plenum of suspended ceiling construction in accordance with the Specimen Conduit Guideline [German designation: MLAR], edition of 10/02/2015, Section 3.5.3.

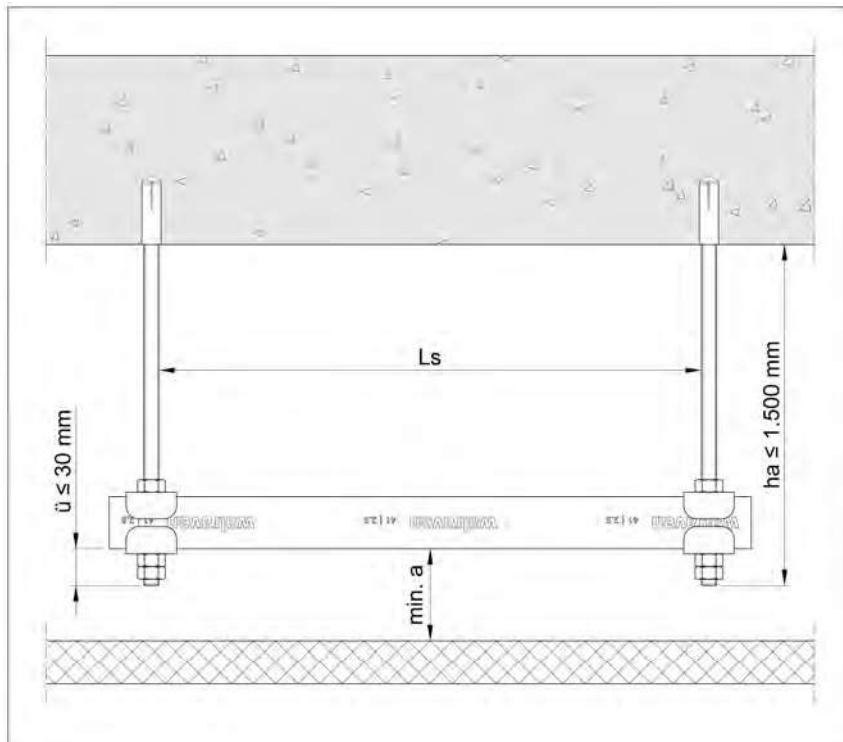

Minimum distance $\text{min. } a \Rightarrow$ minimum distance between topside of a ceiling and underside of the mounting rail.

For combined installations consisting of mounting rails and pipe clamps suspended downwards, the necessary minimum distance $\text{min. } a$ of the individual items installed must be added to a **total minimum distance** $\text{min. } a_{\text{total}}$.

$$\text{min. } a_{\text{total}} = \text{min. } a_{\text{rail}} + \text{min. } a_{\text{clamp}}$$

$\text{min. } a_{\text{total}}$: total distance

$\text{min. } a_{\text{rail}}$: distance in accordance with the following sections

$\text{min. } a_{\text{clamp}}$: distance in accordance with the corresponding test report or expert opinion

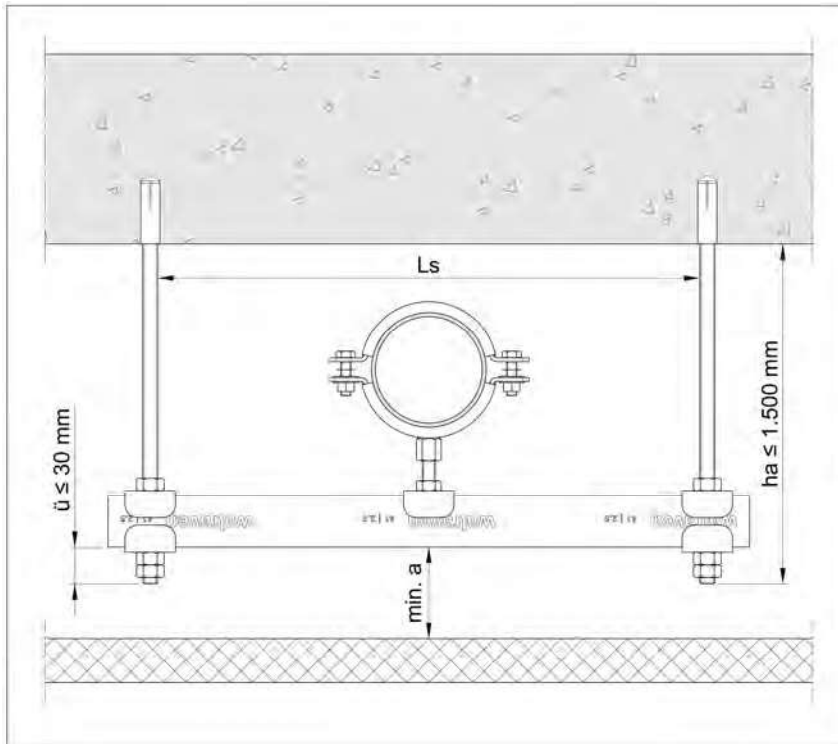

Figure 2: Example of a mounting rail combined with a pipe clamp installation in the ceiling plenum of a suspended ceiling construction in accordance with the Specimen Conduit Guideline [German designation: MLAR]), edition of 10/02/2015, Section 3.5.3

The following assessment for the BIS RapidStrut® Fixing Rails excludes direct use of the system for structures, which, as a total system (e.g. for cable systems designed to maintain circuit integrity and cable trunking/ducts in accordance with DIN 4102-12: 1998-11) are required to meet the requirements of a particular classification (functional integrity or fire resistance classification). For these types of applications, further assessments and tests of the system as a whole are necessary.

Independent of the fire-safety-related assessment, the suitability of the BIS RapidStrut® Fixing Rails combined with threaded rods, fastenings and the substrate must also be proved for the cold as-installed condition. If for the normal purpose of use, smaller loads apply according to the Technical Data Sheets [4] from J. van Walraven Holding B.V, these shall be binding.

3.1 Assessment of BIS RapidStrut® Fixing Rails in conjunction with threaded rods

The proposals for assessment for BIS RapidStrut® Fixing Rails under tensile load and exposure to fire in accordance with DIN EN 1363-1 can be taken from the annexes.

Steel failure

With regard to the load-bearing behaviour under exposure to fire, steel failure and substrate failure can be distinguished.

For the BIS RapidStrut® Fixing Rails assessed here, the failure of the BIS RapidStrut® Fixing Rails combined with threaded rods (steel failure) was decisive. The proof of the fastening system to the substrate has to be furnished separately.

The following sections contain proposals for assessment for BIS RapidStrut® Fixing Rails with regard to the loading of the fixing rails combined with threaded rods as a function of the fire resistance time.

$N_{\text{fire}(t)}$ ⇒ loadbearing capacity under exposure to fire as a function of the time

Deformation

From the fire-safety-related point of view for BIS RapidStrut® Fixing Rails, and provided the respective minimum distance $\min. a$ (see Fig. 1) is observed and the deformation $f_{\text{max}(t)}$ of the fixing rails is taken into account, an impairment of parts arranged on the underside (e.g., a suspended ceiling) by the fixing rails combined with threaded rods can be excluded.

The following sections contain proposals for assessment for BIS RapidStrut® Fixing Rails (load cases: single load and multiple load) with regard to the deformation of the fixing rail combined with threaded rods as a function of the fire resistance time and the suspension height.

$f(t)$ ⇒ deformations as a function of the load, the time and the suspension height

3.1.1 Assessment with regard to maximal loading and maximal deformation of the BIS RapidStrut® Fixing Rails as a function of the fire resistance

Annexes 15 to 24 contain proposals for assessment with regard to the maximal loads and maximal deformations (for single loads and uniformly distributed loads) as a function of the fire resistance time for the BIS RapidStrut® Fixing Rails combined with threaded rods under exposure to fire in accordance with DIN EN 1363-1. The deformation corresponds to the sum of the deflection and the change in length of the fixing rail combined with the threaded rods that occur during exposure to fire. The values for the deformations are indicated as a function of the suspension height.

$\max. N_{\text{fire}(t)}$ ⇒ design value of maximal loadbearing capacity as a function of the fire resistance time

$f_{\text{max}(t)}$ ⇒ maximal deformations as a function of the load (single load / uniformly distributed load), the time and the suspension height

The assessment of the individual systems can be taken from the annexes:

Annexes 15 to 19: Assessment for “Suspended assembly, single load”

Annexes 20 to 22: Assessment for “Suspended assembly, uniformly distributed load”

Annex 23: Assessment for “Suspended assembly, brackets”

Annex 24: Assessment for “Direct assembly”

4 Special notes

- 4.1 This Expert Opinion applies only in terms of fire protection. Further requirements may result from the applicable technical building regulations for conduits and the individual state building code and regulations for special constructions, e.g. with regard to building physics, statics, electrical engineering, ventilation engineering, and similar.
- 4.2 This Expert Opinion is no certificate of suitability for use in a building control procedure. The manufacturer/erector of the construction is obliged to furnish the respective proof.

- 4.3 The above assessment applies only for BIS RapidStrut® Fixing Rails, taking the boundary conditions from the technical data sheets of J. van Walraven Holding B.V, into account.
- 4.4 The assessment applies only for BIS RapidStrut® Fixing Rails fastened in solid structural components. The substrate and the fastening in the substrate must have at least the same fire resistance as the individual fixing rails.
- 4.5 The validity of this Expert Opinion ends on 21/11/2024.
- 4.6 The validity of this Expert Opinion can be extended upon request and as a function of the state of the art.

This document is the translated version of Expert Opinion No. 3184/198/12 – CM dated 21/11/2019. The legally binding text is the aforementioned German Expert Opinion.

i.A.
ORR Dr.-Ing. Blume
Head of Department



i.A.
Dipl.-Ing. Maertins
Engineer/Official in Charge

Technical data ¹⁾: BIS RapidStrut® Rail Systems

Product table: BIS RapidStrut® Rail Systems

No.	Description	Item no.	Material
1	BIS RapidStrut® Fixing Rail ≥ 41x41x2,5 mm (pg)	650 5 x45 650 5 x65 650 5 x85	Steel 1.0242 (pre-galvanized)
	BIS RapidStrut® Fixing Rail ≥ 41x41x2,5 mm (BUP)	6501 8 x47 6501 8 x67 6501 8 687	Steel 1.0242 (BIS UltraProtect® 1000)
2	BIS RapidStrut® Cantilever Arm ≥ 41x41x2,5 mm (BUP)	660 3 86x 660 3 87x	Steel 1.0226 (BIS UltraProtect® 1000)
3	BIS RapidStrut® Base Plate (BUP)	6658 8 5400	Steel 1.0332 (BIS UltraProtect® 1000)
	BIS Strut Base Plate (zp)	6658 3 804	Steel 1.0332 (zinc plated)
4	BIS Strut Washer - U-shaped Ø 11 mm (BUP)	6658 8 010	Steel 1.0332 (BIS UltraProtect® 1000)
	BIS Strut Washer - U-shaped Ø 13 mm (BUP)	6658 8 012	Steel 1.0332 (BIS UltraProtect® 1000)
5	BIS RapidStrut® Hammerfix M10 or M12 (BUP)	6527 8 500x 6527 8 520x	Steel 1.0332 (BIS UltraProtect® 1000)
	BIS RapidStrut® Slide Nut M10 or M12 (BUP)	6651 8 5110 6651 8 5112	Steel 1.0332 (BIS UltraProtect® 1000)
6	BIS Hexagonal Nut M10 or M12 (zp)	612 3 010 612 3 012	DIN 934 (ISO 4032), FK 8 (zinc plated)
	BIS Hexagonal Nut M10 or M12 (BUP)	6128 1 010 6128 1 012	DIN 934 (ISO 4032), FK 8 (BIS UltraProtect® 1000)
7	BIS Threaded Rod M10 or M12 (zp)	630 3 x10 630 3 x12	DIN 976-1, FK ≥ 4.8 (zinc plated)
	BIS Threaded Rod M10 or M12 (BUP)	6308 x 010 6308 x 012	DIN 976-1, FK ≥ 4.8 (BIS UltraProtect® 1000)
8	BIS Strut Slide Nut M10 or M12 (zp)	651 7 010 651 7 012	Steel 1.0332 (zinc plated)
	BIS Strut Slide Nut M10 or M12 (BUP)	6518 8 010 6518 8 012	Steel 1.0332 (BIS UltraProtect® 1000)
9	BIS RapidStrut® Slide Nut with Plastic Tabs M10 or M12 (zp)	651 8 610 651 8 612	Steel 1.0332 (zinc plated)
	BIS RapidStrut® Slide Nut with Plastic Tabs M10 or M12 (BUP)	6518 6 8010 6518 6 8012	Steel 1.0332 (BIS UltraProtect® 1000)
10	Pipe Clamp	---	Exemplary illustration for pipe clamps with fire protec- tion certificate
11	Anchor	---	Exemplary illustration for anchors with fire protection certificate

¹⁾ Manufacturer information

Product overview: BIS RapidStrut® Fixing Rails

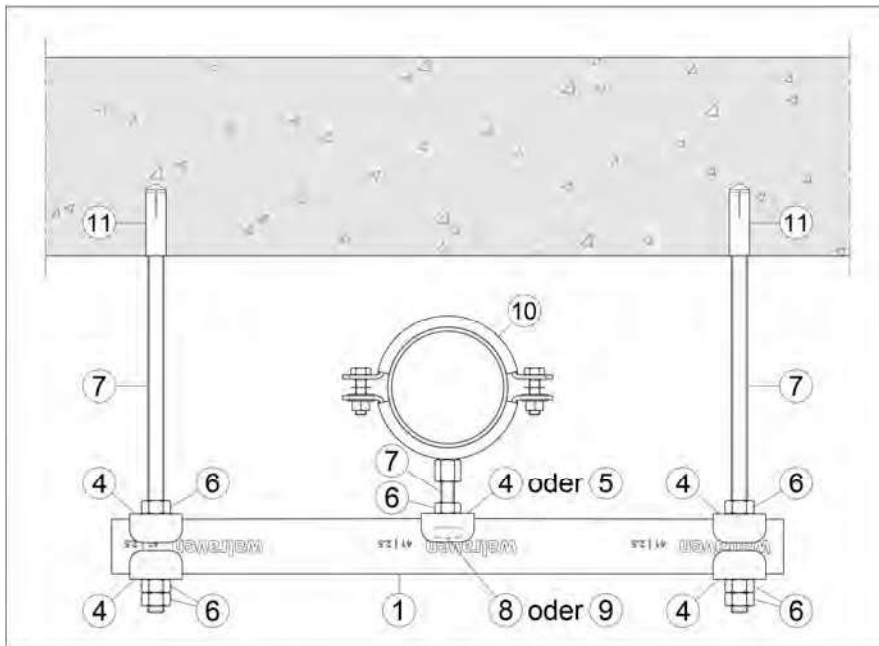

Figure: Execution as suspended assembly

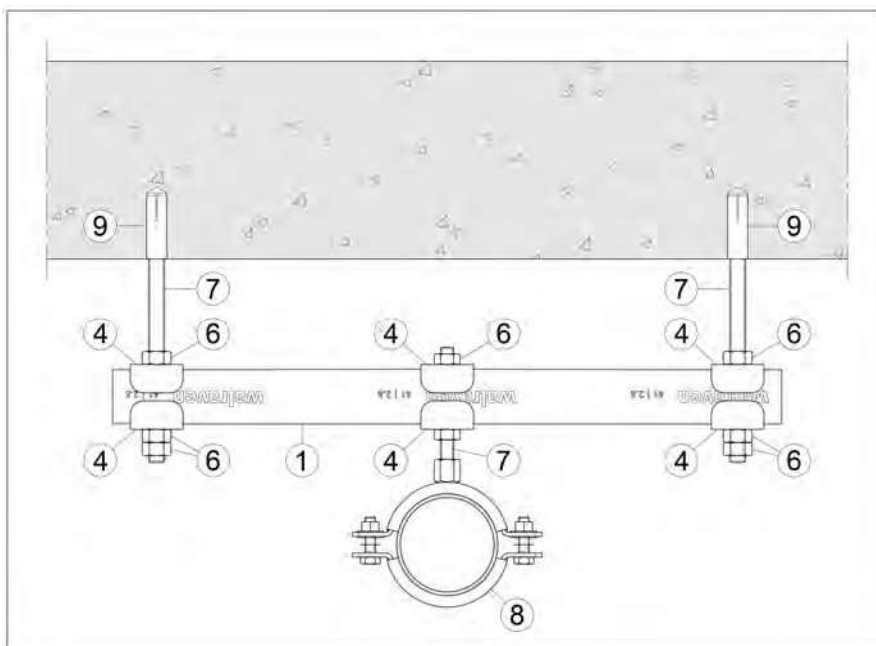

Figure: Execution as suspended assembly with suspended pipe clamps

Product overview: BIS RapidStrut® Fixing Rails

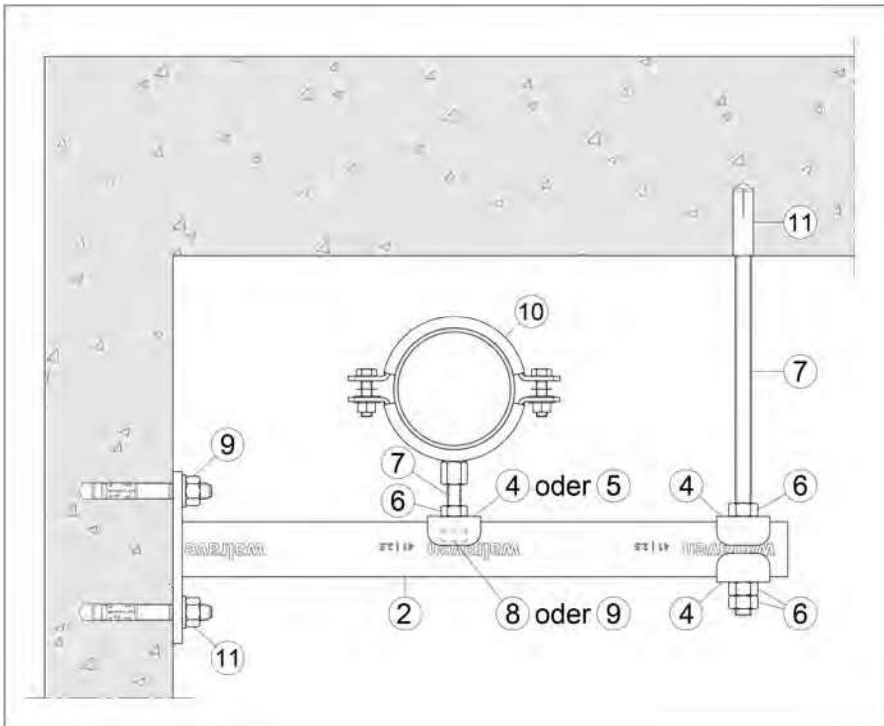

Figure: Execution as suspended assembly combined with brackets

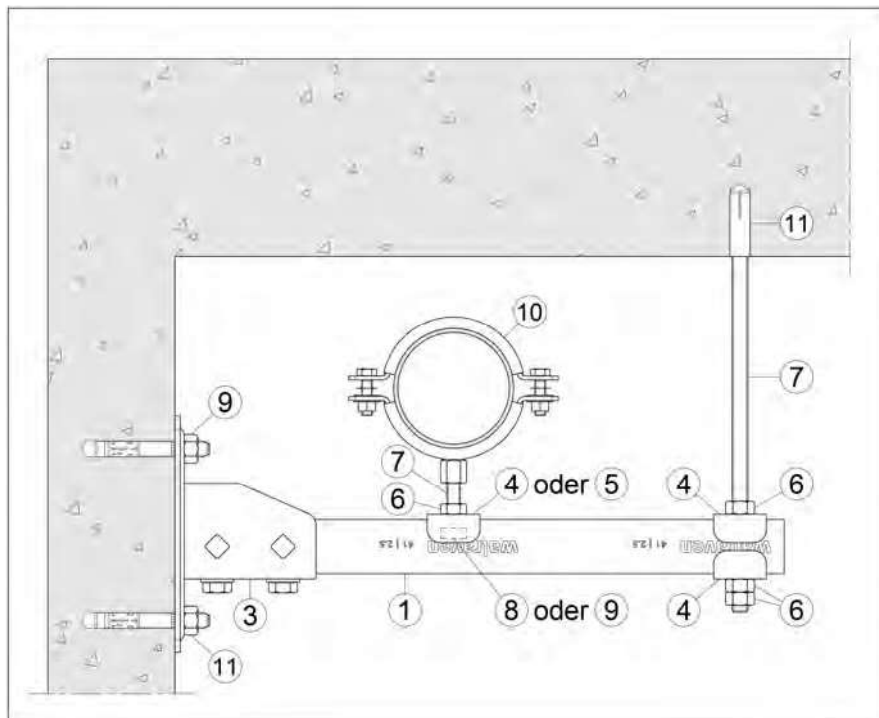

Figure: Execution as suspended assembly combined with brackets

Product overview: BIS RapidStrut® Fixing Rails

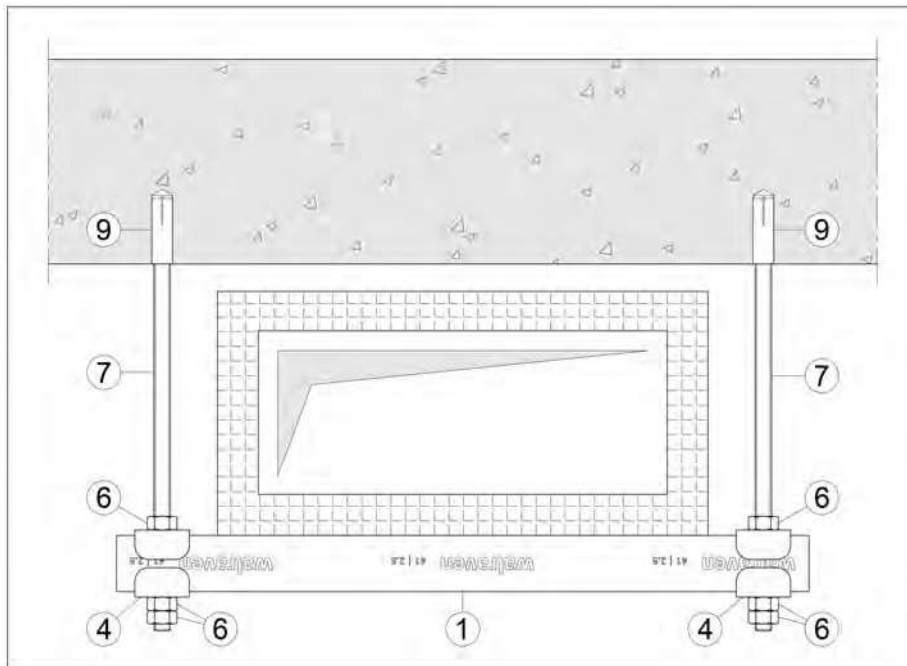

Figure: Execution as suspended assembly (“uniformly distributed load”)

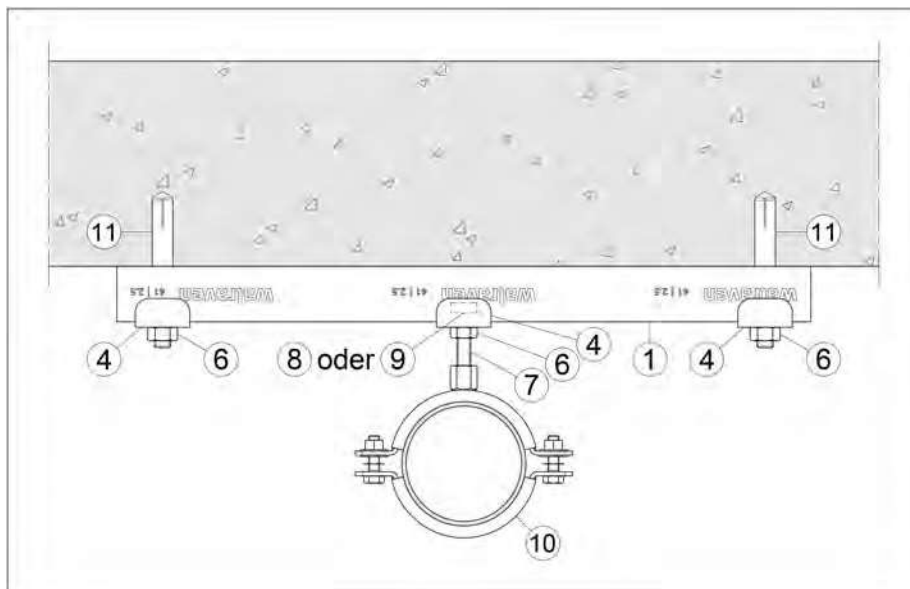

Figure: Execution as direct assembly

BIS RapidStrut® Fixing Rail (pg)

suspension and support



Features and benefits

- universal rail system
- with continuous perforation
- distance between rail end and first hole is always equal
- a continuous graduated centimetre scale on one side
- inward formed flanges with serrated profile for extra grip
- pre-galvanized
- material: steel 1.0242
- Part No. 650 5 X85 (Strut 2.5 mm) material: steel 1.0332
- yield strength 240 N/mm²

Part No.	Model	L	B	H	s	S	RAL	BndS	BndL	App.
			(mm)	(mm)	(mm)	(mm)				
6505245	Perforated	2 m	41	41	2.50	22	RAL ¹	20	100	m.
6505345	Perforated	3 m	41	41	2.50	22	RAL ¹	30	150	m.
6505645	Perforated	6 m	41	41	2.50	22	RAL ¹	60	300	m.
6505365	Perforated	3 m	41	62	2.50	22	-	30	90	m.
6505665	Perforated	6 m	41	62	2.50	22	-	60	180	m.
6505385	Perforated	3 m	41	82	2.50	22	-	180	-	m.
6505685	Perforated	6 m	41	82	2.50	22	-	60	180	m.

RAL¹ = tested, certified and monitored by a third party according to RAL-GZ 655/C.

Strut 41x41x2.5 and above tested for fire safety.

For detailed technical information about our RAL marked products, please see the RAL datasheet in our web catalogue.

For more information about the max. allowed load ($F_{0,z}$) please refer to the loading tables or our online datasheet 'Technical Details BIS RapidStrut®'.

Manufacturer information

BIS RapidStrut® Fixing Rail (BUP1000)

suspension and support

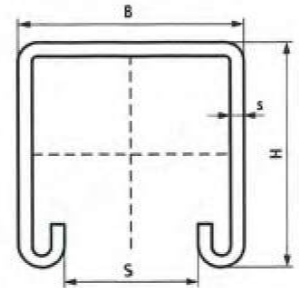

Features and benefits

- universal rail system
- corrosion protection remains intact after cutting
- with continuous perforation
- distance between rail end and first hole is always equal
- a continuous graduated centimetre scale on one side
- inward formed flanges with serrated profile for extra grip
- material: steel 1.0242
- surface protection:
 - product is part of the BIS UltraProtect® 1000 system
 - suitable for in- and outdoor applications
 - stands min. 1,000 hours salt spray test (max. 5% red rust) according to ISO 9227

Part No.	L	B	H	s	S	RAL	BndS	BndL	App.
		(mm)	(mm)	(mm)	(mm)				
65018247	2 m	41	41	2.50	22	RAL ¹	20	100	m.
65018347	3 m	41	41	2.50	22	RAL ¹	30	150	m.
65018647	6 m	41	41	2.50	22	RAL ¹	60	300	m.
65018667	6 m	41	62	2.50	22	-	36	216	m.
65018687	6 m	41	82	2.50	22	-	-	180	m.

RAL¹ = tested, certified and monitored by a third party according to RAL-GZ 655/C.

Strut 41x41x2.5 and above tested for fire safety.

For detailed technical information about our RAL marked products, please see the RAL datasheet in our web catalogue.

For more information about the max. allowed load ($F_{0,2}$) please refer to the loading tables or our online datasheet Technical Details BIS RapidStrut®.

Manufacturer information

BIS RapidStrut® Cantilever Arm (BUP1000)

fixing to wall

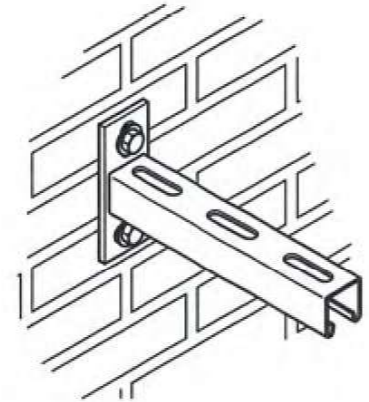

Features and benefits

- wall plate welded on Strut Profile
- slots at 90° to each other to simplify fixing
- CO₂ welded
- inward formed flanges with serrated profile for extra grip
- material: steel 1.0226
- surface protection:
 - product is part of the BIS UltraProtect® 1000 system
 - suitable for in- and outdoor applications
 - stands min. 1,000 hours salt spray test (max. 5% red rust) according to ISO 9227

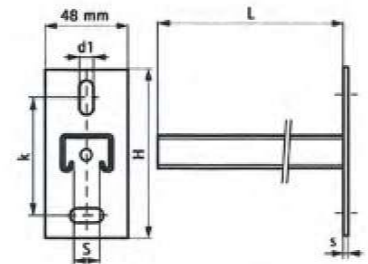

Part No.	L	H	h	s	d1	S	k	From rail	Pack 1
		(mm)	(mm)	(mm)	(mm)	(mm)	(mm)		
6603861	150 mm	130	87.5	7.0	30 x 13	22	87.5	Strut 41x41x2.5	10
6603870	200 mm	130	87.5	7.0	30 x 13	22	87.5	Strut 41x41x2.5	10
6603862	300 mm	130	87.5	7.0	30 x 13	22	87.5	Strut 41x41x2.5	10
6603871	400 mm	130	87.5	7.0	30 x 13	22	87.5	Strut 41x41x2.5	10
6603863	450 mm	130	87.5	7.0	30 x 13	22	87.5	Strut 41x41x2.5	10
6603873	500 mm	130	87.5	7.0	30 x 13	22	87.5	Strut 41x41x2.5	10
6603864	600 mm	130	87.5	7.0	30 x 13	22	87.5	Strut 41x41x2.5	8
6603865	750 mm	130	87.5	7.0	30 x 13	22	87.5	Strut 41x41x2.5	8
6603866	1,000 mm	130	87.5	7.0	30 x 13	22	87.5	Strut 41x41x2.5	1
6603867	1,200 mm	130	87.5	7.0	30 x 13	22	87.5	Strut 41x41x2.5	1

Strut 41x41x2.5 and above tested for fire safety.

For more information about the max. allowed load (F_{a2}) please refer to the loading tables or our online datasheet 'Technical Details BIS RapidStrut®'.

Manufacturer information

BIS RapidStrut® Base Plate G2 (BUP1000)



Features and benefits

- flexible base plate for Strut rails
- suitable for all Strut rail up to 82mm height
- open side of rails 41x41 can be turned to all sides
- at high loads we advise to install with throughbolts
- timesaving with pre-assembled fasteners
- material: metal parts made of steel 1.0332; spring(s) made of POM (polyoxymethylene), green
- surface protection:
 - product is part of the BIS UltraProtect® 1000 system
 - suitable for in- and outdoor applications
 - stands min. 1,000 hours salt spray test (max. 5% red rust) according to ISO 9227

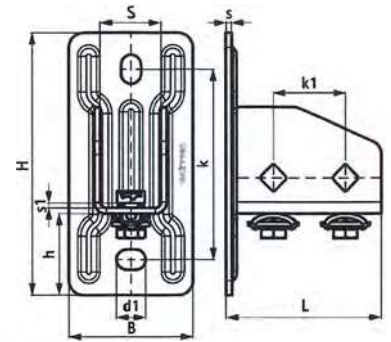

Part No.	L	B	H	h	s	d1	S	k	k1	$F_{a,z}$	$F_{a,z 2}$	$M_{a,y}$	Pack 1
		(mm)	(mm)	(mm)	(mm)	(mm)	(mm)	(mm)	(mm)	(N)	(N)	(Nm)	
665885400	107 mm	85	180	56	4.0	20 x 14	42	130	50	3,636	5,151	485.0	10
<i>F_{o,z}</i> : max. allowed load in combination with 2 slide nuts M10, tightened with 40 Nm.													
<i>F_{o,z 2}</i> : max. allowed load in combination with 2 throughbolts M10, tightened with 40 Nm.													
<i>M_{o,y}</i> : max. moment in combination with 2 throughbolts M10, tightened with 40 Nm.													

Manufacturer information

BIS Strut Base Plate G2 (zp)



Features and benefits

- flexible base plate for Strut rails
 - suitable for all Strut rail up to 82mm height
 - open side of rails 41x41 can be turned to all sides
 - at high loads we advise to install with throughbolts
 - material: steel
- zinc plated

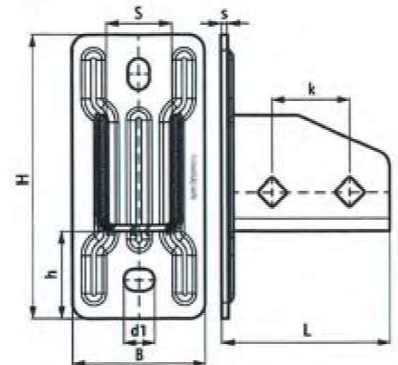

Part No.	L	B	H	h	s	d1	S	k	$F_{a,z}$ (N)	$F_{a,z,2}$ (N)	$M_{a,y}$ (Nm)	Pack 1
66583804	107 mm	85 (mm)	180 (mm)	56 (mm)	4.0 (mm)	20 x 14 (mm)	42 (mm)	50 (mm)	3,636	5,151	485.0	10

F_{a,z}: max. allowed load in combination with 2 slide nuts M10, tightened with 40 Nm.
F_{a,z,2}: max. allowed load in combination with 2 throughbolts M10, tightened with 40 Nm.
M_{a,y}: max. moment in combination with 2 throughbolts M10, tightened with 40 Nm.

manufacturer information

BIS Strut Washer – U-shaped (BUP1000)

to make Strut rail fabrications

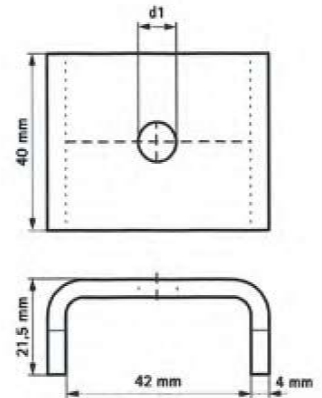

Features and benefits

- U-shaped washer
- U-shaped for extra stability
- material: steel 1.0332
- surface protection:
 - product is part of the BIS UltraProtect® 1000 system
 - suitable for in- and outdoor applications
 - stands min. 1,000 hours salt spray test (max. 5% red rust) according to ISO 9227

Part No.	d1 (mm)	For Rail	Pack 1
66588010	Ø 11.0	Strut	50
66588012	Ø 13.0	Strut	50

*Ø 11.0 and above tested for fire safety.
Also available in stainless steel 1.4401 (AISI 316).*

Manufacturer information

BIS RapidStrut® Hammerfix G2 (BUP1000) fixing to Strut rail

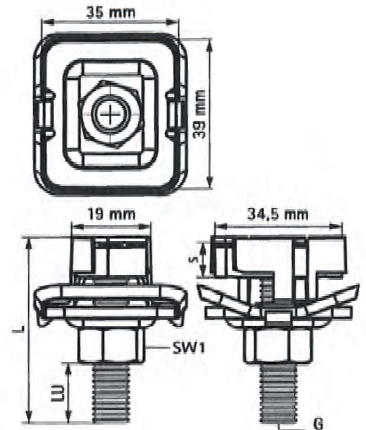

Features and benefits

- slide nut with stud bolt, washer and BIS RapidStrut® spring
- ready-to-use pre-assembled for a quick fixing, and retains assembly in place before final tightening
- material: metal parts made of steel 1.0332; spring(s) made of POM (polyoxymethylene), green
- surface protection:
 - product is part of the BIS UltraProtect® 1000 system
 - suitable for in- and outdoor applications
 - stands min. 1,000 hours salt spray test (max. 5% red rust) according to ISO 9227

Part No.	G	L	LU	s	SW1	T _(max.) (Nm)	F _{a,z} (N)	Pack 1	Pack 2
			(mm)	(mm)	(mm)				
652785004	M10	40 mm	12	8.0	17	15.0	9,500	15	150
652785006	M10	60 mm	32	8.0	17	15.0	9,500	5	100
652785008	M10	80 mm	52	8.0	17	15.0	9,500	5	100
652785204	M12	40 mm	10	9.0	19	30.0	10,000	5	100
652785206	M12	60 mm	30	9.0	19	30.0	10,000	5	100

Tested values in combination with BIS RapidStrut® Rail 41x41x2.5mm.

Manufacturer information

BIS RapidStrut® Slide Nut G2 (BUP1000)

fixing to Strut rail

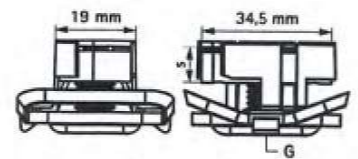
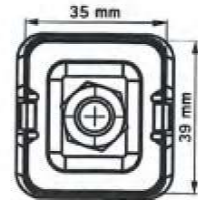

Features and benefits

- slide nut with washer and BIS RapidStrut® spring
- ready-to-use pre-assembled for a quick fixing, and retains assembly in place before final tightening
- material: metal parts made of steel 1.0332; spring(s) made of POM (polyoxymethylene), green
- surface protection:
 - product is part of the BIS UltraProtect® 1000 system
 - suitable for in- and outdoor applications
 - stands min. 1,000 hours salt spray test (max. 5% red rust) according to ISO 9227

Part No.	G	s (mm)	T _(max.) (Nm)	For Rail	F _{a,z} (N)	Pack 1	Pack 2
665185110	M10	8.0	15.0	Strut	9,500	20	200
665185112	M12	9.0	30.0	Strut	10,000	20	200

Tested values in combination with BIS RapidStrut® Rail 41x41x2.5mm.

Manufacturer information

BIS Strut Slide Nut (zp)

fixing to Strut rail

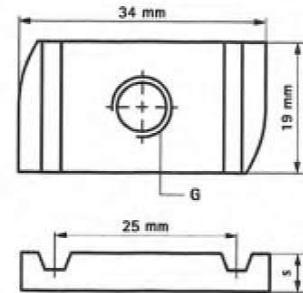

Features and benefits

- material: steel 1.0332
- zinc plated

Part No.	G	L	s (mm)	T _(max.) (Nm)	For Rail	F _{ax} (N)	Pack 1	Pack 2
6517010	M10	-	9.0	15.0	Strut	9,500	100	600
6517012	M12	-	9.0	30.0	Strut	10,000	100	500

M10 and above tested for fire safety.

BIS Strut Slide Nut (BUP1000)

fixing to Strut rail

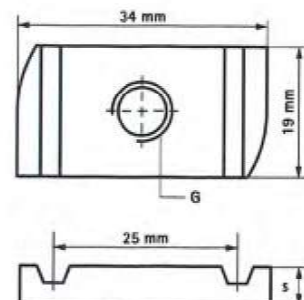

Features and benefits

- for all types of Strut Rail
- for tight fixing of accessories (e.g. connectors) on rail
- material: steel 1.0332
- surface protection:
 - product is part of the BIS UltraProtect® 1000 system
 - suitable for in- and outdoor applications
 - stands min. 1,000 hours salt spray test (max. 5% red rust) according to ISO 9227

Part No.	G	s (mm)	T _(max.) (Nm)	For Rail	F _{ax} (N)	Pack 1
65188008	M8	6.0	15.0	Strut	6,000	100
65188010	M10	8.0	15.0	Strut	9,500	100

Manufacturer information

BIS RapidStrut® Slide Nut with Plastic Tabs (zp)

fixing to Strut rail

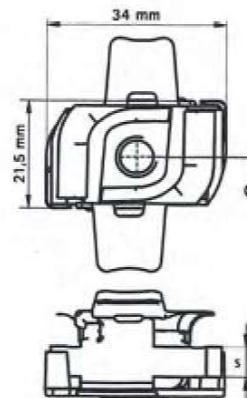

Features and benefits

- slide nut with plastic 'tabs'
- for all types of Strut Rail
- for tight fixing of accessories (e.g. connectors) on rail
- with plastic tabs which simplifies inserting and positioning
- material: slide nut made of steel 1.0332;
- tabs made of PP (polypropylene), green
- zinc plated

Part No.	G	s (mm)	T _(max.) (Nm)	For Rail	F _{a,z} (N)	Pack 1
6518610	M10	9.0	15.0	Strut	9,500	100
6518612	M12	9.0	30.0	Strut	10,000	100

M10 and above tested for fire safety.

BIS RapidStrut® Slide Nut with Plastic Tabs (BUP1000)

fixing to Strut rail

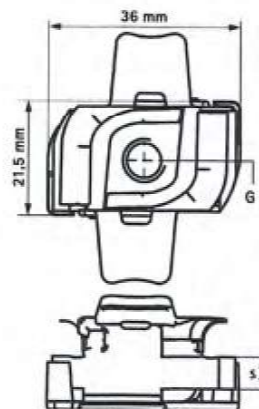

Features and benefits

- slide nut with plastic 'tabs'
- for all types of Strut Rail
- for tight fixing of accessories (e.g. connectors) on rail
- with plastic tabs which simplifies inserting and positioning
- material: slide nut made of steel 1.0332;
- tabs made of PP (polypropylene), green
- surface protection:
 - product is part of the BIS UltraProtect® 1000 system
 - suitable for in- and outdoor applications
 - stands min. 1,000 hours salt spray test (max. 5% red rust) according to ISO 9227

Part No.	G	s (mm)	T _(max.) (Nm)	For Rail	F _{a,z} (N)	Pack 1
651868010	M10	8.0	15.0	Strut	9,500	100
651868012	M12	9.0	30.0	Strut	10,000	100

M10 and above tested for fire safety.

Manufacturer information

Proposal for assessment for BIS RapidStrut® Fixing Rails under tensile load and exposure to fire in accordance with DIN EN 1363-1 (suspended assembly)

Table 2: Proposal for assessment for mounting systems with BIS RapidStrut® Fixing Rails combined with related threaded rods as a function of the fire resistance time (30 minutes)

Fire resistance: 30 minutes		BIS RapidStrut® Fixing Rail ≥ 41 x 41 x 2.5 combined with threaded rods "suspended assembly"				
Static span	[mm]	400	500	600	700	800
Load case		Maximum load [kN]				
Total amount of uniformly distributed load	[kN]	3.30	3.25	3.15	3.00	2.80
1 single load à ≤	[kN]	1.10	1.10	1.10	1.10	1.10
2 single load à ≤		0.79	0.72	0.68	0.65	0.63
3 single load à ≤		0.76	0.63	0.56	0.51	0.48
4 single load à ≤		-	0.62	0.52	0.45	0.41
5 single load à ≤		-	-	0.51	0.43	0.38
6 single load à ≤		-	-	-	0.42	0.36
7 single load à ≤		-	-	-	-	0.35

Table 3: Proposal for assessment for mounting systems with BIS RapidStrut® Fixing Rails combined with related threaded rods as a function of the fire resistance time (60 minutes)

Fire resistance: 60 minutes		BIS RapidStrut® Fixing Rail ≥ 41 x 41 x 2.5 combined with threaded rods "suspended assembly"				
Static span	[mm]	400	500	600	700	800
Load case		Maximum load [kN]				
Total amount of uniformly distributed load	[kN]	1.90	1.85	1.75	1.65	1.50
1 single load à ≤	[kN]	0.70	0.70	0.70	0.70	0.70
2 single load à ≤		0.49	0.45	0.42	0.40	0.39
3 single load à ≤		0.45	0.38	0.34	0.31	0.29
4 single load à ≤		-	0.36	0.30	0.27	0.24
5 single load à ≤		-	-	0.29	0.25	0.22
6 single load à ≤		-	-	-	0.24	0.20
7 single load à ≤		-	-	-	-	0.19

Proposal for assessment for BIS RapidStrut® Fixing Rails under tensile load and exposure to fire in accordance with DIN EN 1363-1 (suspended assembly)

Table 4: Proposal for assessment for mounting systems with BIS RapidStrut® Fixing Rails combined with related threaded rods as a function of the fire resistance time (90 minutes)

Fire resistance: 90 minutes		BIS RapidStrut® Fixing Rail ≥ 41 x 41 x 2.5 combined with threaded rods "suspended assembly"				
Static span	[mm]	400	500	600	700	800
Load case		Maximum load [kN]				
Total amount of uniformly distributed load	[kN]	1.40	1.35	1.30	1.20	1.05
1 single load à ≤	[kN]	0.55	0.55	0.55	0.55	0.55
2 single load à ≤		0.38	0.34	0.33	0.31	0.30
3 single load à ≤		0.34	0.29	0.26	0.24	0.22
4 single load à ≤		-	0.27	0.23	0.20	0.18
5 single load à ≤		-	-	0.22	0.19	0.16
6 single load à ≤		-	-	-	0.18	0.15
7 single load à ≤		-	-	-	-	0.14

Table 5: Proposal for assessment for mounting systems with BIS RapidStrut® Fixing Rails combined with related threaded rods as a function of the fire resistance time (120 minutes)

Fire resistance: 120 minutes		BIS RapidStrut® Fixing Rail ≥ 41 x 41 x 2.5 combined with threaded rods "suspended assembly"				
Static span	[mm]	400	500	600	700	800
Load case		Maximum load [kN]				
Total amount of uniformly distributed load	[kN]	1.10	1.05	1.00	0.90	0.80
1 single load à ≤	[kN]	0.45	0.45	0.45	0.45	0.45
2 single load à ≤		0.30	0.28	0.26	0.25	0.24
3 single load à ≤		0.27	0.23	0.21	0.19	0.18
4 single load à ≤		-	0.21	0.18	0.16	0.14
5 single load à ≤		-	-	0.17	0.14	0.13
6 single load à ≤		-	-	-	0.13	0.11
7 single load à ≤		-	-	-	-	0.10

Deformations (f_{max}) for BIS RapidStrut® Fixing Rails under tensile load and exposure to fire in accordance with DIN EN 1363-1 Suspended assembly, “single load”)

Table 6: Deformations (f_{max}) for mounting systems with BIS RapidStrut® Fixing Rails combined with related threaded rods as a function of the time, the span, the suspension height and the load (single load, centrally)

Deformation: 30 to 120 minutes				BIS RapidStrut® Fixing Rail ≥ 41 x 41 x 2,5 combined with threaded rods “suspended assembly”											
Static span	l_s	≤	[mm]	400											
Suspension height	h_a	≤	[mm]	500				1000				1500			
Single load	P	≤	[kN]	1.10	0.70	0.55	0.45	1.10	0.70	0.55	0.45	1.10	0.70	0.55	0.45
Time [min]				Deformations (f_{max}) [mm]											
30 minutes				190	40	40	40	195	45	45	45	200	50	50	50
60 minutes					160	50	40		165	55	45		170	60	50
90 minutes				---	---	150	110	---	---	155	115	---	---	160	120
120 Minutes					---	---	210		---	---	215		---	---	220

Table 7: Deformations (f_{max}) for mounting systems with BIS RapidStrut® Fixing Rails combined with related threaded rods as a function of the time, the span, the suspension height and the load (single load, centrally)

Deformation: 30 to 120 minutes				BIS RapidStrut® Fixing Rail ≥ 41 x 41 x 2.5 combined with threaded rods “suspended assembly”											
Static span	l_s	≤	[mm]	500											
Suspension height	h_a	≤	[mm]	500				1000				1500			
Single load	P	≤	[kN]	1.10	0.70	0.55	0.45	1.10	0.70	0.55	0.45	1.10	0.70	0.55	0.45
Time [min]				Deformations (f_{max}) [mm]											
30 minutes				230	70	40	40	235	75	45	45	240	80	50	50
60 minutes					190	80	60		195	85	65		200	90	70
90 minutes				---	---	180	140	---	---	185	145	---	---	190	150
120 minutes					---	---	220		---	---	225		---	---	230

Deformations (f_{max}) for BIS RapidStrut® Fixing Rails under tensile load and exposure to fire in accordance with DIN EN 1363-1 Suspended assembly, “single load”)

Table 8: Deformations (f_{max}) for mounting systems with BIS RapidStrut® Fixing Rails combined with related threaded rods as a function of the time, the span, the suspension height and the load (single load, centrally)

Deformation: 30 to 120 minutes				BIS RapidStrut® Fixing Rail ≥ 41 x 41 x 2.5 combined with threaded rods “suspended assembly”											
Static span	l_s	≤	[mm]	600											
Suspension height	h_a	≤	[mm]	500				1000				1500			
<u>Single load</u>	P	≤	[kN]	1.10	0.70	0.55	0.45	1.10	0.70	0.55	0.45	1.10	0.70	0.55	0.45
Zeit [min]				Deformations (f_{max}) [mm]											
30 minutes				270	180	150	60	275	185	155	65	280	190	160	70
60 minutes					225	185	160		230	190	165		235	195	170
90 minutes				---		215	200	---		220	205	---		225	210
120 minutes					---		240		---		245		---		250

Table 9: Deformations (f_{max}) for mounting systems with BIS RapidStrut® Fixing Rails combined with related threaded rods as a function of the time, the span, the suspension height and the load (single load, centrally)

Deformation: 30 to 120 minutes				BIS RapidStrut® Fixing Rail ≥ 41 x 41 x 2.5 combined with threaded rods “suspended assembly”											
Static span	l_s	≤	[mm]	700											
Suspension height	h_a	≤	[mm]	500				1000				1500			
<u>Single load</u>	P	≤	[kN]	1.10	0.70	0.55	0.45	1.10	0.70	0.55	0.45	1.10	0.70	0.55	0.45
Zeit [min]				Deformations (f_{max}) [mm]											
30 minutes				330	250	240	170	335	255	245	175	340	260	250	180
60 minutes					270	250	230		275	255	235		280	260	240
90 minutes				---		260	250	---		265	255	---		270	260
120 minutes					---		270		---		275		---		280

Deformations (f_{max}) for BIS RapidStrut® Fixing Rails under tensile load and exposure to fire in accordance with DIN EN 1363-1 Suspended assembly, “single load”)

Table 10: Deformations (f_{max}) for mounting systems with BIS RapidStrut® Fixing Rails combined with related threaded rods as a function of the time, the span, the suspension height and the load (single load, centrally)

Deformation: 30 to 120 minutes				BIS RapidStrut® Fixing Rail ≥ 41 x 41 x 2.5 combined with threaded rods “suspended assembly”											
Static span	l_s	≤	[mm]	800											
Suspension height	h_a	≤	[mm]	500				1000				1500			
Single load	P	≤	[kN]	1.10	0.70	0.55	0.45	1.10	0.70	0.55	0.45	1.10	0.70	0.55	0.45
Zeit [min]	Deformations (f_{max}) [mm]														
30 minutes				400	300	250	190	405	305	255	195	410	310	260	200
60 minutes					320	290	280		325	295	285		330	300	290
90 minutes				---		300	290	---		305	295	---		310	300
120 minutes						---	310			---	315			---	320

Proposal for assessment and deformations (f_{max}) for BIS RapidStrut® Fixing Rails under tensile load and exposure to fire in accordance with DIN EN 1363-1 (suspended assembly, “uniformly distributed load”)

Table 11: Deformations (f_{max}) for mounting systems with BIS RapidStrut® Fixing Rails combined with related threaded rods as a function of the time, the span, the suspension height and the load (uniformly distributed load)

Deformation: 30 to 120 minutes				BIS RapidStrut® Fixing Rail ≥ 41 x 41 x 2.5 combined with threaded rods “suspended assembly”											
Static span	l_s	≤	[mm]	400											
Suspension height	h_a	≤	[mm]	500				1000				1500			
Uniformly distributed load	q	≤	[kN]	3.30	1.90	1.40	1.10	3.30	1.90	1.40	1.10	3.30	1.90	1.40	1.10
Zeit [min]				Deformations (f_{max}) [mm]											
30 minutes				110	60	40	40	115	65	45	45	120	70	50	50
60 minutes					125	80	40		130	85	45		135	90	50
90 minutes				---		100	65	---		105	70	---		110	75
120 minutes							90				95				100

Table 12: Deformations (f_{max}) for mounting systems with BIS RapidStrut® Fixing Rails combined with related threaded rods as a function of the time, the span, the suspension height and the load (uniformly distributed load)

Deformation: 30 to 120 minutes				BIS RapidStrut® Fixing Rail ≥ 41 x 41 x 2.5 combined with threaded rods “suspended assembly”											
Static span	l_s	≤	[mm]	500											
Suspension height	h_a	≤	[mm]	500				1000				1500			
Uniformly distributed load	q	≤	[kN]	3.25	1.85	1.35	1.05	3.25	1.85	1.35	1.05	3.25	1.85	1.35	1.05
Zeit [min]				Deformations (f_{max}) [mm]											
30 minutes				150	70	40	40	155	75	45	45	160	80	50	50
60 minutes					150	95	50		155	100	55		160	105	60
90 minutes				---		125	80	---		130	85	---		135	90
120 minutes							115				120				125

Proposal for assessment and deformations (f_{max}) for BIS RapidStrut® Fixing Rails under tensile load and exposure to fire in accordance with DIN EN 1363-1 (suspended assembly, “uniformly distributed load”)

Table 13: Deformations (f_{max}) for mounting systems with BIS RapidStrut® Fixing Rails combined with related threaded rods as a function of the time, the span, the suspension height and the load (uniformly distributed load)

Deformation: 30 to 120 minutes				BIS RapidStrut® Fixing Rail ≥ 41 x 41 x 2.5 combined with threaded rods “suspended assembly”											
Static span	l_s	≤	[mm]	600											
Suspension height	h_a	≤	[mm]	500				1000				1500			
Uniformly distributed load	q	≤	[kN]	3.15	1.75	1.30	1.00	3.15	1.75	1.30	1.00	3.15	1.75	1.30	1.00
Zeit [min]				Deformations (f_{max}) [mm]											
30 minutes				200	85	50	40	205	90	55	45	210	95	60	50
60 minutes					170	115	80		175	120	85		180	125	90
90 minutes				---		155	115	---		160	120	---		165	125
120 minutes					---	---	145		---	---	150		---	---	155

Table 14: Deformations (f_{max}) for mounting systems with BIS RapidStrut® Fixing Rails combined with related threaded rods as a function of the time, the span, the suspension height and the load (uniformly distributed load)

Deformation: 30 to 120 minutes				BIS RapidStrut® Fixing Rail ≥ 41 x 41 x 2.5 combined with threaded rods “suspended assembly”											
Static span	l_s	≤	[mm]	700											
Suspension height	h_a	≤	[mm]	500				1000				1500			
Uniformly distributed load	q	≤	[kN]	3.00	1.65	1.20	0.90	3.00	1.65	1.20	0.90	3.00	1.65	1.20	0.90
Zeit [min]				Deformations (f_{max}) [mm]											
30 minutes				260	110	50	40	265	115	55	45	270	120	60	50
60 minutes					200	145	120		205	150	125		210	155	130
90 minutes				---		190	150	---		195	155	---		200	160
120 minutes					---	---	180		---	---	185		---	---	190

Proposal for assessment and deformations (f_{max}) for BIS RapidStrut® Fixing Rails under tensile load and exposure to fire in accordance with DIN EN 1363-1 (suspended assembly, “uniformly distributed load”)

Table 15: Deformations (f_{max}) for mounting systems with BIS RapidStrut® Fixing Rails combined with related threaded rods as a function of the time, the span, the suspension height and the load (uniformly distributed load)

Deformation: 30 to 120 minutes				BIS RapidStrut® Fixing Rail ≥ 41 x 41 x 2.5 combined with threaded rods “suspended assembly”											
Static span	l_s	≤	[mm]	800											
Suspension height	h_a	≤	[mm]	500				1000				1500			
<u>Uniformly distributed load</u>	q	≤	[kN]	2.80	1.50	1.05	0.80	2.80	1.50	1.05	0.80	2.80	1.50	1.05	0.80
Zeit [min]				Deformations (f_{max}) [mm]											
30 minutes				330	150	50	40	335	155	55	45	340	160	60	50
60 minutes					230	180	150		235	185	155		240	190	160
90 minutes				---		230	190	---		235	195	---		240	200
120 minutes					---	---	230		---	---	235		---	---	240

Proposal for assessment and deformations (f_{max}) for BIS RapidStrut® Fixing Rails under tensile load and exposure to fire in accordance with DIN EN 1363-1 (“suspended assembly, bracket”)

Table 16: Deformations (f_{max}) for BIS RapidStrut® Fixing Rails, BIS RapidStrut® Cantilever Arm or BIS RapidStrut® Base Plate / BIS Strut Base Plate with BIS RapidStrut® 41x41x2.5 combined with related threaded rods as a function of the time and the span, at a suspension height of 500 mm and under load (single load, centrally)

Fire resistance: 30 to 120 minutes				BIS RapidStrut® Cantilever Arm or BIS RapidStrut® Base Plate / BIS Strut Base Plate with BIS RapidStrut® 41x41x2.5 combined with anchors/threaded rods “suspended assembly, bracket”			
Static span	l_s	\leq	[mm]	700			
Time	t_u		[min]	30	60	90	120
Load case				Maximum load [kN]			
1 Single load	\dot{a}	\leq	[kN]	0.60	0.39	0.30	0.25
2 Single loads	\dot{a}	\leq		0.34	0.22	0.17	0.14
3 Single loads	\dot{a}	\leq		0.25	0.16	0.12	0.09
4 Single loads	\dot{a}	\leq		0.19	0.12	0.08	0.07
5 Single loads	\dot{a}	\leq		0.15	0.09	0.07	0.06
6 Single loads	\dot{a}	\leq		0.12	0.08	0.06	0.05

Deformations for BIS RapidStrut® Fixing Rails under tensile load and exposure to fire in accordance with DIN EN 1363-1 (“suspended assembly, bracket”)

Table 17: Deformations (f_{max}) for BIS RapidStrut® Fixing Rails, BIS RapidStrut® Cantilever Arm or BIS RapidStrut® Base Plate / BIS Strut Base Plate with BIS RapidStrut® 41x41x2.5 combined with related threaded rods as a function of the time and the span, at a suspension height of 500 mm and under load (single load, centrally)

Deformation: 30 to 120 minutes				BIS RapidStrut® Cantilever Arm or BIS RapidStrut® Base Plate / BIS Strut Base Plate with BIS RapidStrut® 41x41x2.5 combined with anchors/threaded rods “suspended assembly, bracket”			
Static span	l_s	\leq	[mm]	700			
Suspension height	h_a	\leq	[mm]	500			
Single load	P	\leq	[kN]	0.60	0.39	0.30	0.25
Zeit [min]				Deformations (f_{max}) [mm]			
30 minutes				180	130	100	80
60 minutes				---	180	150	120
90 minutes					180	150	
120 minutes					---	180	

Above a suspension height of 500 mm and up to a maximum suspension height of 1500 mm, the deformation can be determined by way of calculation, taking the thermal length variation of the system into account.

Deformations for BIS RapidStrut® Fixing Rails under tensile load and exposure to fire in accordance with DIN EN 1363-1 (“direct assembly”)

Table 18: Proposal for assessment for mounting systems with BIS RapidStrut® Fixing Rails combined with related threaded steel rods as a function of the fire resistance time

Fire resistance: 30 to 120 minutes				BIS RapidStrut® Fixing Rail 41 x 41 x 2.5 combined with anchors/threaded rods “direct assembly”			
Static span	l_s	\leq	[mm]	400			
Time	t_u	-	[min]	30	60	90	120
Load case				Maximum load [kN]			
1 Single load	$\dot{\lambda}$	\leq	[kN]	1.00	0.60	0.45	0.35
2 Single loads	$\dot{\lambda}$	\leq		0.58	0.35	0.28	0.20
3 Single loads	$\dot{\lambda}$	\leq		0.42	0.24	0.20	0.17

Deformations for BIS RapidStrut® Fixing Rails under tensile load and exposure to fire in accordance with DIN EN 1363-1 (“direct assembly”)

Table 19: Deformations (f_{max}) for mounting systems with BIS RapidStrut® Fixing Rails as a function of the time, the span and the load (single load, centrally)

Deformation: 30 to 120 minutes				BIS RapidStrut® Fixing Rail 41 x 41 x 2.5 combined with anchors/threaded rods “direct assembly”			
Static span	l_s	\leq	[mm]	400			
Single load	P	\leq	[kN]	1.00	0.60	0.45	0.35
Time [min]				Deformations (f_{max}) [mm]			
30 minutes				40	40	40	40
60 minutes				---	50	40	40
90 minutes					---	50	40
120 minutes					---	---	55