

RapidRail® Wall Plate



Product Specifications:

- Can be mounted to floor or wall
- U-profile CO2 welded on wall plate
- Create a custom cantilever arm by cutting the rail to size and placing into wall plate
- Rail can be fixed with slot downwards or sideways
- Slots at 90° to each other to simplify fixing
- Pre-assembled with RapidRail® Slide Nut(s) for quick installation
- Retains assembly in place before final tightening
- Materials: metal parts made of zinc plated steel 1.0332, spring(s) made of POM (polyoxymethylene)

Item Number	For strut	Items per pkg.
6613200	WM15	25

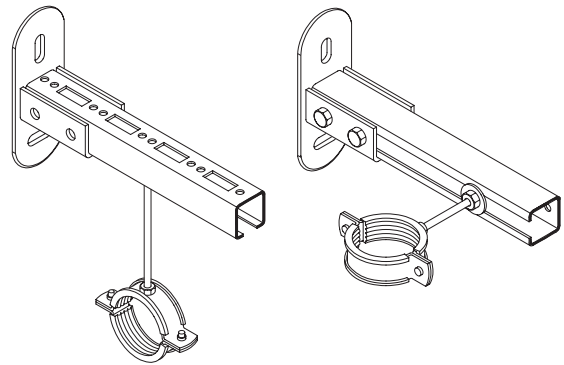
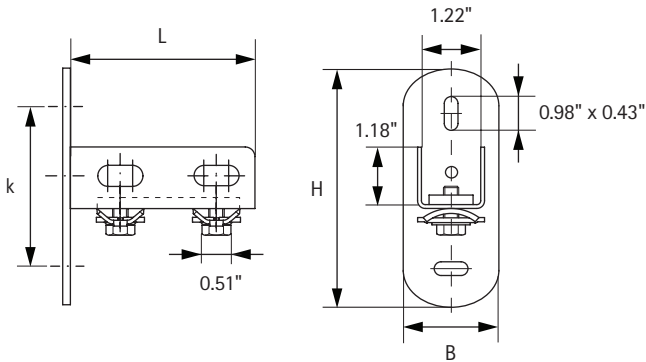

PRODUCT SUBMITTAL		Architect / Owner:
Job Name:		
		Contractor:
Date:		
Part No.	Qty:	Notes:

THE INFORMATION CONTAINED IN THIS SUBMITTAL SHEET IS PROPRIETARY TO WALRAVEN, INC. AND IS SUBJECT TO CHANGE WITHOUT NOTICE. THIS INFORMATION MAY NOT BE REPRODUCED IN PART OR WHOLE WITHOUT WRITTEN AUTHORIZATION FROM WALRAVEN, INC.

