

Technical Information Pacifyre® IWM III Fire Strip



According Annex III of the CPR 305/2011
No. DoP Nr. 0761-CPR-18-0918

Deutschland

Österreich - Schweiz - South East Europe

Walraven GmbH

Karl-von-Linde-Str. 22

D-95447 Bayreuth

Tel. +49 (0)921 75 60 0

Fax +49 (0)921 75 60 111

info.de@walraven.com

Walraven Group

Mijdrecht (NL) • Tienen (BE) • Bayreuth (DE)

Banbury (GB) • Malmö (SE) • Grenoble (FR)

Barcelona (ES) • Kraków (PL) • Mladá Boleslav (CZ)

Moscow (RU) • Kyiv (UA) • Detroit (US)

Shanghai (CN) • Dubai (AE) • Budapest (HU)

Mumbai (IN) • Singapore (SG) • Burlington (CA)

Declaration of Performance

According to Annex III of the Regulation (EU) Nr.305/2011 (Construction Products Regulation).

Pacifyre® System IWM III

Nr. 0761-CPR-18-0918.

1. Unique identification code of the product-type:

- Pacifyre® IWM III.

2. Type, batch or serial number or any element allowing identification of the products.

- Order number. See delivery note.

3. Intended use or uses of the construction product, in accordance with the applicable harmonised technical specification:

- Fire Stopping and Sealing Products for Penetration Seals, see ETA-18/0918.

Pipe Penetrations	Combustible pipes	The field of application has to comply with the content of the ETA-18/0918.
-------------------	-------------------	---

4. Name and contact address:

- J. van Walraven Holding B.V. - Industrieweg 5 - 3641 RK Mijdrecht - The Netherlands.

5. System of assessment and verification of constancy of performance (AVCP) of the construction product:

- System 1.

6. In case of the declaration of performance concerning a construction product covered by a harmonised standard:

- Not applicable.

7. European Assessment Document, European Technical Assessment, Technical Assessment Body & Notified Body:

EAD	ETA	TAB	NB
ETAG 026-2	ETA-18/0918	ETA Danmark A/S	MPA Braunschweig, No. 0761

8. Declared Performance

Essential characteristics	ETA
Reaction to fire	Class E according EN 13501-1
Resistance to fire	In accordance with EN 13501-2. See annex
Dangerous substances	None according TR 034, dated March 2012
Durability and serviceability	Use category Type X
Other	Use category Type X

9. The performance of the product identified in points 1 and 2 is in conformity with the declared performance in point 8.

This declaration of performance is issued under the sole responsibility of the manufacturer identified in point 4.

Signed for and on behalf of the manufacturer by:

Frank Nijdam

Group Director Product Marketing and Innovation

Mijdrecht, 25.04.2017

J. van Walraven Holding B.V.

Annex 1.0

Pacifyre® IWM III general aspects

The verification of durability is part of testing the essential characteristics. The Pacifyre® IWM III with mineral fibre panels may be used in end-use applications according to the provisions for use category Y2 and the Pacifyre® IWM III without mineral fibre panels may be used in end-use applications according to the provisions for use category X without expecting significant changes of the characteristics relevant for fire protection.

Products that meet the requirements for type Y2 also meet the requirements for type Z1 and Z2

It is assumed that:

- Damages to the penetration seal are repaired accordingly.
- The installation of the penetration seal does not affect the stability of the adjacent building element – even in case of fire.
- The installations are fixed to the adjacent building element in accordance with the relevant regulations in such a way that, in case of fire, no additional mechanical load is imposed to the penetration seal.
- The support of the installations is maintained for the required period of the fire resistance.
- Pneumatic dispatch systems, compressed air systems, etc. are switched off by additional means in case of fire.

The risk of downward spread of fire caused by burning material which drips through a pipe to floors below, is not considered in this European Technical Assessment (see EN 1366-3:2009, clause 1).

Always check ETA-18/0918 for the details and the specific pipe wall thicknesses.

Annex 1.1

Pacifyre® IWM III through wall partitions

The below applies to seals in walls with the following specifications:

- The wall must be classified according to EN 13501-2.
- The wall shall be at least 100 mm thick.
- The walls shall be made from concrete, aerated concrete, bricks or a lightweight partition.
- For lightweight partitions, the number of boards on each side shall be at least 2 and the total thickness of the boards on each side shall be at least 25 mm.
- Lightweight partitions made with timber frame shall have at least two boards on each side, and the total thickness of the boards on each side shall be at least 25 mm. No penetration must be closer than 100 mm to a timber batten. The void between the penetration and the timber batten shall be filled with an insulation material with reaction to fire class A1 or A2 according to EN 13501-1.
- The pipes shall penetrate the walls perpendicular to the walls.
- The penetrations shall be made as single penetrations.
- The pipe insulation made from AF/Armaflex shall cover the pipes out to a distance of 350 mm from the surface of the wall on each side.
- The pipe insulation shall be continuous through the penetration.
- The gap between the pipe and the wall shall be between 10 mm and 50 mm wide.
- The pipes may be covered with a PE foam based pipe insulation with a maximum thickness of 4 mm.

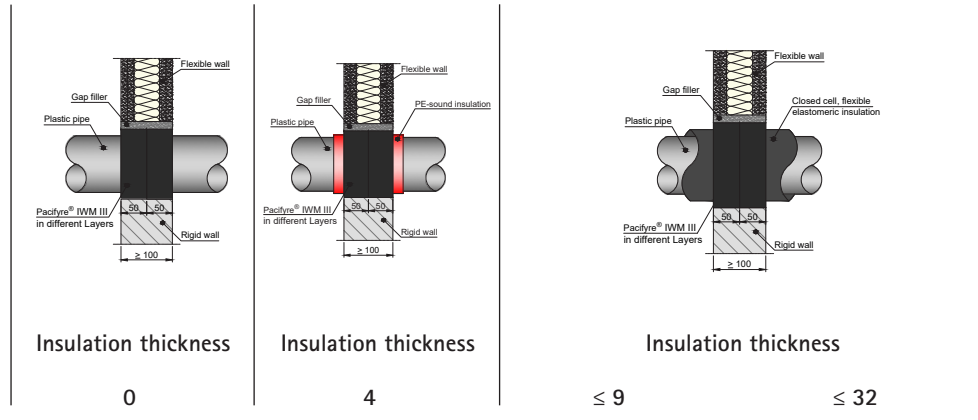

Pipe	Ø mm		# Layers	EI value (U/C)	E value (U/C)	# Layers	EI value (U/C)	E value (U/C)	# Layers	EI value (U/C)	E value (U/C)	# Layers	EI value (U/C)	E value (U/C)	ETA page
	mm	mm													
PVC	≤ 50	1,8 - 5,6	2	120	120	3	120	120	3	120	120	3	120	120	14
	≤ 75	1,8 - 12,3	3	120	120	3	120	120	3	120	120	4	120	120	14
	≤ 110	1,8 - 12,3	3	120	120	3	120	120	3	120	120	4	120	120	14
PE	≤ 50	1,8 - 10	2	120	120	3	120	120	3	120	120	4	120	120	15
	≤ 110	1,8 - 10	3	120	120	3	120	120	3	120	120	4	120	120	15
PP	≤ 50	1,8 - 10	2	120	120	2	120	120	3	120	120	4	120	120	15
	≤ 75	1,8 - 10	3	120	120	3	120	120	4	120	120	4	120	120	15
	≤ 110	1,8 - 10	3	120	120	3	120	120	4	120	120	4	120	120	15
Wavin Si Tech	≤ 50	2,0	-	-	-	2	120	120	-	-	-	-	-	-	16
	≤ 75	2,0 - 2,55	-	-	-	3	120	120	-	-	-	-	-	-	16
	≤ 90	2,0 - 3,05	-	-	-	4	120	120	-	-	-	-	-	-	16
	≤ 110	2,0 - 3,7	-	-	-	5	120	120	-	-	-	-	-	-	16
Aqua-therm green	≤ 40	5,6	2	120	120	2	120	120	2	120	120	2	120	120	16
	≤ 75	5,6 - 10,4	3	120	120	3	120	120	3	120	120	3	120	120	16
	≤ 110	10,4 - 15,2	4	120	120	4	120	120	4	120	120	4	120	120	16
Uponor MLC	≤ 40	5,6	2	120	120	2	120	120	2	120	120	2	120	120	17
	≤ 75	5,6 - 10,4	3	90*	120	3	120	120	3	120	120	3	120	120	17
	≤ 110	10,4 - 15,2	4	90*	120	4	120	120	4	120	120	4	120	120	17
Alpex	≤ 40	3,5	2	120	120	2	120	120	2	120	120	2	120	120	18
	≤ 75	3,5 - 5,0	3	120	120	-	-	-	3	90	120	5	120	120	18

* = EI120 U/C with 1 more layer.

Annex 1.2

Pacifyre® IWM III through floor partitions

Description of the installations for the confirmation of fire resistance in 150 mm concrete slabs.

The below applies to seals in walls with the following specifications:

- The floor must be classified according to EN 13501-2.
- The floor shall be at least 150 mm thick.
- The floor shall be made from concrete or aerated concrete with a density of at least 550 kg/m³.
- The distance between two single Ø 110 mm penetrations shall be at least 100 mm.
- PVC pipes and multilayer pipes Unipipe, Alpex Duo and Fusiotherm Stabigverbund may be installed with less than 100 mm or zero relative distance in a linear distribution. In this case the requirements in the table regarding zero distance shall be observed.
- The pipes shall penetrate the floor perpendicular to the floor.
- The pipe insulation made from AF/Armaflex shall cover the pipes out to a distance of 350 mm from the surface of the floor on each side.
- The pipe insulation shall be continuous through the penetration.
- The gap between the pipe and the floor shall be between 10 mm and 50 mm wide, and shall be filled with an insulation material with reaction to fire class A1 or A2 according to EN 13501-1 or with cement or gypsum based mortar.
- The pipes may be covered with a PE foam based pipe insulation with a maximum thickness of 4 mm.

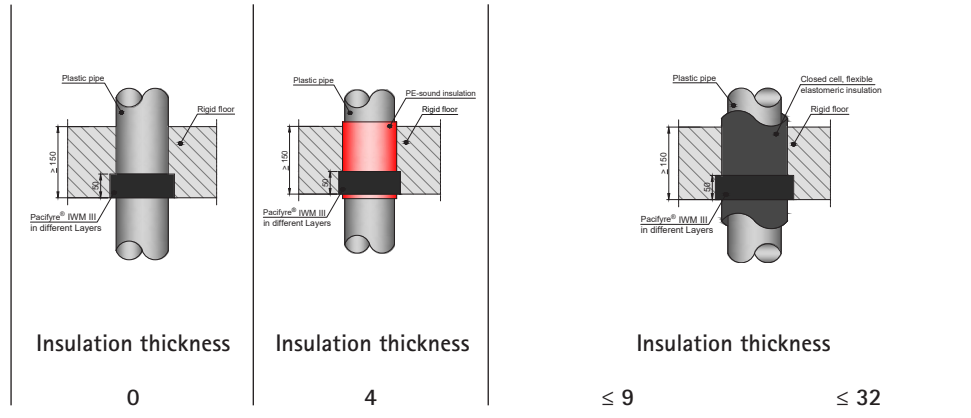

Pipe	Ø mm		# Layers	EI value (U/C)	E value (U/C)	# Layers	EI value (U/C)	E value (U/C)	# Layers	EI value (U/C)	E value (U/C)	# Layers	EI value (U/C)	E value (U/C)	ETA page
	mm	mm													
PVC	≤ 50	1,8 - 5,6	2	120	120	3	120	120	3	120	120	5	90	90	19
	50	3,7	2	240	240	-	-	-	-	-	-	-	-	-	19
	≤ 75	1,8 - 12,3	3	120	120	3	120	120	3	120	120	5	90	90	19
	≤ 110	1,8 - 12,3	2	90	90	2	90	90	2	90	90	3	90	90	23
	≤ 110	1,8 - 12,3	3	120	120	3	120	120	3	120	120	5	90	90	19
	≤ 160	4,7	6	240	240	-	-	-	-	-	-	-	-	-	19
PE	≤ 50	1,8 - 4,6	2	120	120	3	120	120	3	120	120	-	-	-	20
	50	4,6	2	240	240	-	-	-	-	-	-	-	-	-	20
	≤ 75	1,8 - 10	3	120	120	3	120	120	3	120	120	-	-	-	20
	≤ 110	1,8 - 10	3	120	120	3	120	120	3	90	90	4	120	120	20
PP	≤ 50	1,8 - 10	2	120	120	2	120	120	3	120	120	4	120	120	21
	≤ 110	1,8 - 10	3	120	120	3	120	120	3	120	120	4	120	120	21
Wavin SI Tech/ POLO KAL NG/ Geberit Silent PP/Rehau Raupiano	≤ 50	X	-	-	-	2	120	120	-	-	-	-	-	-	21/22/23
	≤ 75	X	-	-	-	3	120	120	-	-	-	-	-	-	21/22/23
	≤ 90	X	-	-	-	4	120	120	-	-	-	-	-	-	21/22/23
	≤ 110	X	-	-	-	5	120	120	-	-	-	-	-	-	21/22/23
Aquatherm Green	≤ 40	1,8 - 5,6	2	90	90	2	90	90	2	90	90	3	90	90	23
	≤ 40	5,6	2	120	120	2	120	120	2	120	120	2	120	120	24
	≤ 75	1,8 - 10,4	2	90	90	2	90	90	2	90	90	2	90	90	23
	≤ 75	5,6 - 10,4	3	120	120	3	120	120	3	120	120	3	120	120	24
	≤ 110	1,8 - 12,3	2	90	90	2	90	90	2	90	90	2	90	90	23
	≤ 110	10,4 - 15,2	4	120	120	4	120	120	4	120	120	4	120	120	24
Multilayer	≤ 40	1,8 - 5,6	2	90	90	2	90	90	2	90	90	3	90	90	23
	≤ 40	5,6	2	120	120	2	120	120	2	120	120	2	120	120	24
	≤ 75	1,8 - 10,4	2	90	90	2	90	90	2	90	90	2	90	90	23
	≤ 75	5,6 - 10,4	3	120	120	3	120	120	3	120	120	3	120	120	24
	≤ 110	1,8 - 12,3	2	90	90	2	90	90	2	90	90	2	90	90	23
	≤ 110	10,4 - 15,2	4	120	120	4	120	120	4	120	120	4	120	120	24
Alpex Duo	≤ 40	1,8 - 3,5	2	90	90	2	90	90	2	90	90	3	90	90	23
	≤ 40	3,5	2	120	120	-	-	-	-	-	-	-	-	-	25
	≤ 75	1,8 - 5	2	90	90	2	90	90	2	90	90	3	90	90	23
	≤ 75	3,5 - 5	3	120	120	3	90	120	3	120	120	4	120	120	25
	≤ 75	1,8 - 5	-	-	-	5	120	120	-	-	-	-	-	-	25

X = pipe wall thickness is fixed in diameter range, see technical data of the specific pipe range.

Annex 1.3

Pacifyre® IWM III though mineral wool board partitions (wall & floor)

The below applies to seals in walls with the following specifications:

- The wall or floor must be classified according to EN 13501-2.
- The wall shall be at least 100 mm thick, floor 150mm thick.
- The walls or floors shall be made from concrete, aerated concrete.
- Walls can also be made from bricks or a lightweight partition.
- For lightweight partition walls, the number of boards on each side shall be at least 2 * 12,5mm plasterboards according to EN520, the total thickness of the boards on each side shall be at least 25 mm.
- For lightweight partition walls the void between the boards shall be filled with 50 mm mineral wool with reaction to fire Euroclass A1 (100 kg/m3) according to EN 13501-1.
- Lightweight partition walls made with timber frame shall have at least two boards on each side, and the total thickness of the boards on each side shall be at least 25 mm. No penetration must be closer than 100 mm to a timber batten. The void between the penetration and the timber batten shall be filled with an 100mm insulation material with reaction to fire class A1 or A2 according to EN 13501-1.
- The thickness of the mineral fibre sealant must be at least 2 x 50 mm.
- The pipes shall penetrate the partition perpendicular to the wall or floor.

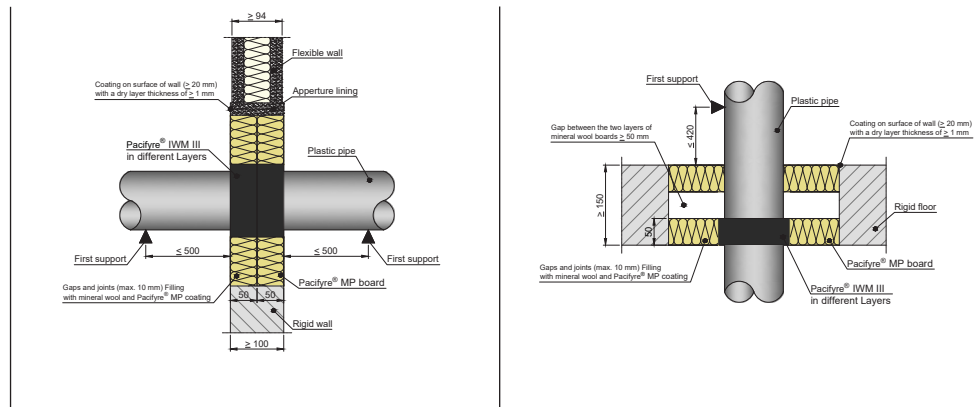

Pipe	Ø mm		# Layers	EI value U/U	E vaue U/U	ETA page	# Layers	EI value U/U	E value U/U	ETA page
	↺	↻								
PVC	≤ 50	2,4	2	120	120	26	2	60	120	27
	≤ 75	3,6	3	120	120	26	3	120	120	27
	≤ 110	5,3	4	120	120	26	4	90	120	27
	≤ 160	7,7	-	-	-	-	6	90	120	27
PP	≤ 50	2,9	2	120	120	26	2	60	120	27
	≤ 75	4,3	3	120	120	26	3	120	120	27
	≤ 110	6,3	6	120	120	26	4	90	120	27
	≤ 160	9,1	6	120	120	26	6	120	120	27

Annex 1.4

Pacifyre® IWM III through double gypsum board partitions (wall)

Description of the installations for the confirmation of fire resistance in shaft walls of $\geq 2 \times 20$ mm thickness.

The below applies to seals in walls with the following specifications:

- The shaft wall must be classified according to EN 13501-2.
- The shaft wall shall be at least 2×20 mm thickness and, when needed, doubling up around the pipe of 2×20 mm.
- For the divided shaft wall, the number of boards shall be at least $2 * 20$ mm plasterboards according to EN15283, the total thickness of the boards shall be at least 40 mm.
- For the shaft wall the CW50 profiles shall be mounted with max. c/c 1000mm distance.
- The pipe penetration distance to the nearest mounting must be max. 300 mm.
- The pipe penetration to other cables etc. must be min. 100 mm.
- The pipes shall penetrate the walls perpendicular to the walls.
- The pipe wrap will be only in the middle of the shaft wall.
- The shaft wall was tested from both sides during the official test in the test laboratory.

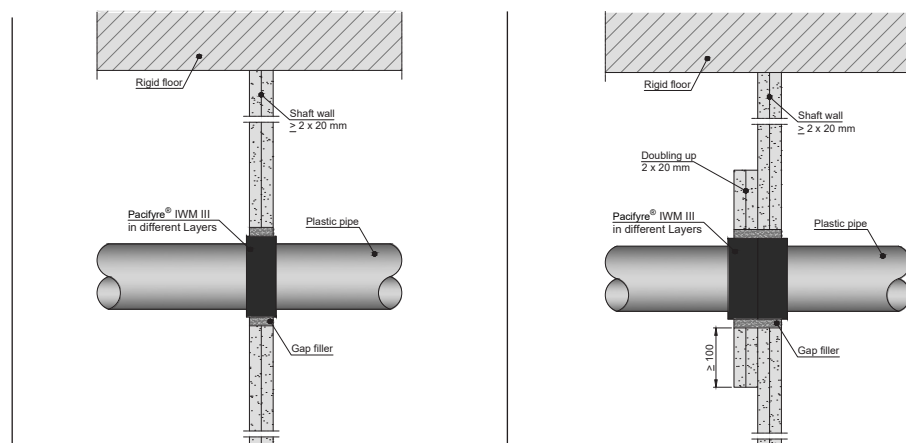

Pipe	Ø mm		# Layers	EI value	E value	ETA page	# Layers	EI value	E value	ETA page
	mm	mm								
PVC	50	3,7	2	90 U/U	90 U/U	28	-	-	-	-
	110	5,3	4	90 U/C	90 U/C	28	4	120 U/C	120 U/C	29
PE	50	4,6	2	90 U/U	90 U/U	28	-	-	-	-
	110	6,3	4	90 U/C	90 U/C	28	4	120 U/C	120 U/C	29
PP	50	4,6	2	90 U/U	90 U/U	28	-	-	-	-
	110	6,3	4	90 U/C	90 U/C	28	4	120 U/C	120 U/C	29