

Technical Information BIS Pacifyre® AMW II Conduit Fire Collar

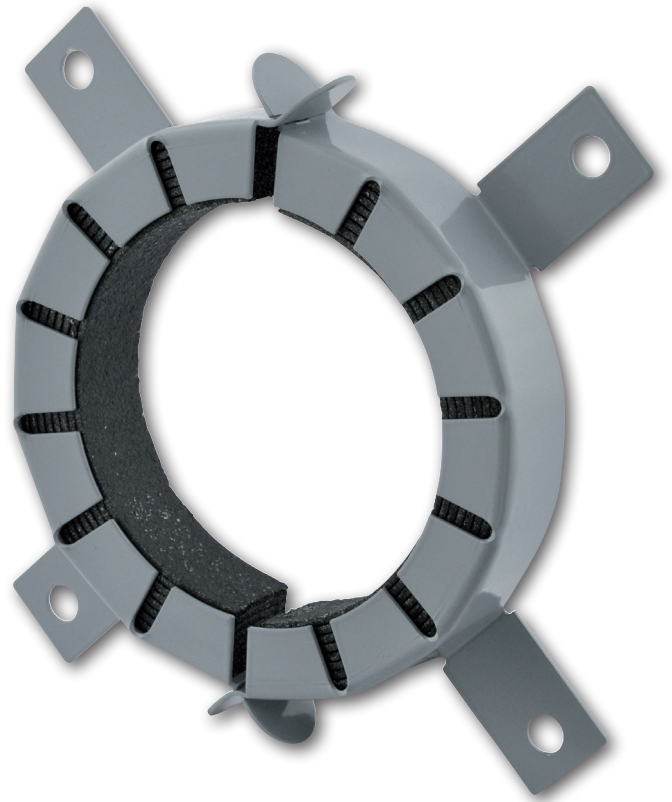

European Technical Assessment
ETA-11/0372

- Sealing of cable tubes -

Deutschland

Österreich - Schweiz - South East Europe

Walraven GmbH

Karl-von-Linde-Str. 22

D-95447 Bayreuth

Tel. +49 (0)921 75 60 0

Fax +49 (0)921 75 60 111

info.de@walraven.com

Walraven Group

Mijdrecht (NL) • Tienen (BE) • Bayreuth (DE)

Banbury (GB) • Malmö (SE) • Grenoble (FR)

Barcelona (ES) • Kraków (PL) • Mladá

Boleslav (CZ) • Moscow (RU) • Kyiv (UA)

Detroit (US) • Shanghai (CN) • Dubai (AE)

Budapest (HU)



Austrian Institute of Construction Engineering
Schenkenstrasse 4 | T+43 1 533 65 50
1010 Vienna | Austria | F+43 1 533 64 23
www.oib.or.at | mail@oib.or.at



European Technical Assessment

ETA-11/0372
of 01.09.2017

General part

Technical Assessment Body issuing the European Technical Assessment

Österreichisches Institut für Bautechnik (OIB)
Austrian Institute of Construction Engineering

Trade name of the construction product

ROKU® System AWM II - KS

Product family to which the construction product belongs

Fire Stopping and Fire Sealing Products:
Penetration Seals

Manufacturer

Rolf Kuhn GmbH
Jägersgrund 10
57339 Erndtebrück
GERMANY

Manufacturing plant

Rolf Kuhn GmbH
Jägersgrund 10
57339 Erndtebrück
GERMANY

This European Technical Assessment contains

30 pages including Annexes A-1 to F-4 which form an integral part of this assessment

This European Technical Assessment is issued in accordance with Regulation (EU) No 305/2011, on the basis of

Guideline for European technical approval for "Fire Stopping and Fire Sealing Products", ETAG 026 Part 2: "Penetration Seals", edition August 2011, used as European Assessment Document (EAD)

This European Technical Assessment replaces

European technical approval ETA-11/0372 with validity from 08.11.2011 to 07.11.2016

This European Technical Assessment is not to be transferred to manufacturers or agents of manufacturer other than those indicated on page 1, or manufacturing plants other than those laid down in the context of this European Technical Assessment.

Translations of this European Technical Assessment in other languages shall fully correspond to the original issued document and should be identified as such.

Communication of this European Technical Assessment, including transmission by electronic means, shall be in full. However, partial reproduction can be made with the written consent of the Österreichisches Institut für Bautechnik. In this case, partial reproduction has to be designated as such.

This European Technical Assessment may be withdrawn by the Österreichisches Institut für Bautechnik, in particular pursuant to information by the Commission according to Article 25 (3) of Regulation (EU) No 305/2011.

electronic copy
electronic copy
electronic copy
electronic copy
electronic copy
electronic copy

Specific parts

1 Technical description of the product

“ROKU® System AWM II - KS” is kit to be used as cable penetration seal based on the pipe collar “ROKU® AWM II - KS” in combination with gap fillers and sealing materials (additional components).

Pipe collar	Characteristics
ROKU® AWM II - KS	Pipe collar according to Annex B-1 of the ETA with sheet steel housing and an inlay made of intumescent material (ROKU® Strip)

Gap fillers (additional components)	Characteristics
Gap filler	Non-combustible material with classification A1 or A2-s1,d0 according to EN 13501-1 which is dimensionally stable as e.g. mortar, cement or gypsum joint filler

Sealing materials (additional components)	Characteristics
ROKU® AC Brandschutzkitt	Intumescent fire stop mastic from manufacturer “Rolf Kuhn GmbH” – filled in cartridges
Kerafix® Brandschutzsilikon	1-component silicone sealant, neutral-curing from manufacturer “Rolf Kuhn GmbH” with classification E according to EN 13501-2 – filled in cartridges

2 Specification of the intended use(s) in accordance with the applicable European Assessment Document

2.1 Intended use

“ROKU® System AWM II - KS” is intended to be used as cable penetration seal to temporarily or permanently reinstate the fire resistance performance of flexible wall constructions, rigid wall constructions and rigid floor constructions where they have been provided with apertures which are penetrated by bundles of plastic conduits (with or without cables), including single penetrations.

“ROKU® System AWM II - KS” can be installed only in the types of separating elements as specified in the following table.

Separating element	Construction
Flexible walls	<ul style="list-style-type: none"> > Steel studs or timber studs lined on both faces with minimum 2 layer of boards (minimum thickness 12,5 mm) with classification A2-s1,d0 or A1 according to EN 13501-1 > For timber stud walls there shall be a minimum distance of 100 mm of the penetration seal to any timber stud. The cavity between the penetration seal and the timber stud has to be closed with minimum 100 mm of insulation with classification A1 or A2 according to EN 13501-1 > Minimum thickness 94 mm > Classification according to EN 13501-2: ≥ EI 120 > This European Technical Assessment does not cover sandwich panel constructions and flexible walls where the lining does not cover studs on both sides. Penetrations in such constructions shall be tested on a case by case basis
Rigid walls ¹	<ul style="list-style-type: none"> > Aerated concrete, concrete, masonry > Minimum thickness 100 mm > The rigid wall shall be classified in accordance with EN 13501-2 for the required fire resistance period
	<ul style="list-style-type: none"> > Aerated concrete, concrete, masonry > Minimum density 600 kg/m³ > Minimum thickness 150 mm > The rigid wall shall be classified in accordance with EN 13501-2 for the required fire resistance period
Rigid floors	<ul style="list-style-type: none"> > Aerated concrete, concrete > Minimum density 500 kg/m³ > Minimum thickness 150 mm > The rigid floor shall be classified in accordance with EN 13501-2 for the required fire resistance period

¹ This European Technical Assessment refers to rigid walls with a minimum thickness of 100 mm, if not stated otherwise (see Annex C-2, Annex D-2, Annex D-4, Annex D-6, Annex D-7 and Annex D-9 to Annex D-11 of the ETA).

electronic copy

“ROKU® System AWM II - KS” can only be configured as specified in the following tables. Other parts or service support constructions shall not penetrate the penetration seal.

Penetrating element	Construction characteristics for installation of the penetrating element in flexible walls, rigid walls and rigid floors
Conduits	<ul style="list-style-type: none"> <li data-bbox="491 448 1495 683">> Bundles² of plastic conduits “FFKuS-EM-F Highspeed” (also available as “FFKuS-EM-F grau”) made of PVC-U (with / without cables³ Ø ≤ 21 mm) with a maximum outer diameter ≤ 125 mm: “FFKuS-EM-F Highspeed” from manufacturer “FRÄNKISCHE ROHRWERKE Gebr. Kirchner GmbH & Co. KG” (conduit acc. to EN 61386-22) with Ø 16 mm to 63 mm and wave heights as defined in Annex D-1, Annex D-2, Annex D-5, Annex D-6, Annex F-1 and Annex F-2 of the ETA <li data-bbox="491 694 1495 976">> Bundles⁴ of plastic conduits “FFKuS-EM-F-105 Highspeed” (also available as “FFKuS-EM-F-105”) made of polyolefine (with / without cables⁵ Ø ≤ 21 mm) with a maximum outer diameter ≤ 125 mm: “FFKuS-EM-F-105 Highspeed” from manufacturer “FRÄNKISCHE ROHRWERKE Gebr. Kirchner GmbH & Co. KG” (conduit acc. to EN 61386-22) with Ø 16 mm to 63 mm and wave heights as defined in Annex D-3, Annex D-4, Annex D-7, Annex D-8, Annex F-3 and Annex F-4 of the ETA

2.2 Use category

“ROKU® System AWM II - KS” is intended for use in conditions exposed to weathering and can therefore – according to ETAG 026-Part 2 clause 2.4.12.1.3.3 – be categorized as Type X. Since the requirements for Type X are met, also the requirements for Type Y₁, Y₂, Z₁ and Z₂ are fulfilled.

Although a penetration seal is intended for indoor applications only, the construction process may result in it being subjected to more exposed conditions for a period before the building envelope is closed. For this case provisions shall be made to protect temporarily exposed penetration seals according to the ETA-holder’s installation instructions.

2.3 Working life

The provisions made in this European Technical Assessment are based on an assumed working life of “ROKU® System AWM II - KS” of 10 years, provided the conditions laid down in the technical literature of the manufacturer relating to packaging, transport, storage, installation, use and repair are met.

The indications given on the intended working life cannot be interpreted as a guarantee given by the producer or the Technical Assessment Body, but are to be regarded only as a means for selecting the appropriate product in relation to the expected economically reasonable working life of the works.

The real working life might be, in normal use conditions, considerably longer without major degradation affecting the Basic requirements for construction works.

² Including single penetrations
³ All types of sheathed cables (single or multicore cable with individual insulation of the cores and an additional protective covering of the assembly), except waveguides, currently and commonly used in building practice in Europe (e.g. electrical / telecommunication / data / optical fibre cables)
⁴ Including single penetrations
⁵ All types of sheathed cables (single or multicore cable with individual insulation of the cores and an additional protective covering of the assembly), except waveguides, currently and commonly used in building practice in Europe (e.g. electrical / telecommunication / data / optical fibre cables)

electronic copy

2.4 General assumptions

2.4.1 It is assumed that

- > damages to the penetration seal are repaired accordingly,
- > the installation of the penetration seal does not effect the stability of the adjacent building element – even in case of fire,
- > the lintel or floor above the penetration seal is designed structurally and in terms of fire protection such that no additional mechanical load (other than its own weight) is imposed on the penetration seal,
- > the thermal movement in the pipe work will be accommodated in such way that it does not impose a load on the penetration seal,
- > the installations are fixed to the adjacent building element in accordance with the relevant regulations in such a way that, in case of fire, no additional mechanical load is imposed to the penetration seal,
- > the support of the installations is maintained for the required period of fire resistance.

2.4.2 This European Technical Assessment does not verify the prevention of destruction of adjacent building elements with fire separating function or of the installations due to distortion forces caused by extreme temperatures.

The mounting or hanging of the installations shall be implemented in such a way that the pipes and the fire resistant building elements shall remain functional within a period of time which corresponds to the fire resistance period required.

2.4.3 The assessment does not cover the avoidance of destruction of the penetration seal or of the adjacent building element(s) by forces caused by temperature changes in case of fire.

2.5 Manufacturing

The European Technical Assessment is issued for the product on the basis of agreed data/information, deposited with the Österreichisches Institut für Bautechnik, which identifies the product that has been assessed and judged. Changes to the product or production process, which could result in this deposited data/information being incorrect, should be notified to the Österreichisches Institut für Bautechnik before the changes are introduced.

The Österreichisches Institut für Bautechnik will decide whether or not such changes affect the European Technical Assessment and consequently the validity of the CE marking on the basis of the European Technical Assessment and if so whether further assessment or alterations to the European Technical Assessment, shall be necessary.

3 Performance of the product and references to the methods used for its assessment

Basic requirements for construction works	Essential characteristic	Method of verification	Performance
BWR 2	Reaction to fire	EN 13501-1	Clause 3.1.1 of the ETA
	Resistance to fire	EN 13501-2: 2007+A1:2009	Clause 3.1.2 of the ETA and Annex D-1 to D-8 and Annex F-1 to F-4 of the ETA
BWR 3	Air permeability (material property)	No performance assessed	
	Water permeability (material property)	No performance assessed	
	Content and/or release of dangerous substances	European Council Directive 67/548/EEC and Regulation (EC) No 1272/2008 as well as EOTA TR 034, edition October 2015	Declaration of conformity by the manufacturer
BWR 4	Mechanical resistance and stability	No performance assessed	
	Resistance to impact / movement	No performance assessed	
	Adhesion	No performance assessed	
BWR 5	Airborne sound insulation	No performance assessed	
BWR 6	Thermal properties	No performance assessed	
	Water vapour permeability	No performance assessed	

3.1 Safety in case of fire (BWR 2)

3.1.1 Reaction to fire

The components of "ROKU® System AWM II - KS" were assessed according to ETAG 026-Part 2 clause 2.4.1 and classified according to EN 13501-1.

Pipe collar	Class according to EN 13501-1
Intumescent inlay of ROKU® AWM II - KS	E
Sheet steel housing of ROKU® AWM II - KS	A1

3.1.2 Resistance to fire

“ROKU® System AWM II - KS” was tested according to ETAG 026-Part 2 clause 2.4.2 and EN 1366-3:2009 in conjunction with EN 1363-1:1999.

Based upon the gained test results and the field of application specified within EN 1366-3:2009 the cable penetration seal “ROKU® System AWM II - KS” has been classified according to EN 13501-2:2007+A1:2009.

The fire resistance classes of the cable penetration seal “ROKU® System AWM II - KS” in the relevant separating elements are listed in Annex D-1 to Annex D-8 and Annex F-1 to Annex F-4 of the ETA.

The resistance to fire classification listed in Annex D-1 to Annex D-8 and Annex F-1 to Annex F-4 of the ETA is only valid if “ROKU® System AWM II - KS” is installed according to Annex A-1 to Annex A-4 of the ETA.

3.2 Hygiene, health and environment (BWR 3)

3.2.1 Air permeability

No performance assessed.

3.2.2 Water permeability

No performance assessed.

3.2.3 Release of dangerous substances

According to the manufacturer’s declaration the components of “ROKU® System AWM II - KS” do not contain dangerous substances detailed in Council Directive 67/548/EEC and Regulation (EC) no 1272/2008 as well as EOTA TR 034 (General BWR 3 Checklist for EADs/ETAs – Dangerous substances), edition October 2015.

A written declaration in this respect was submitted by the ETA-holder.

In addition to the specific clauses relating to dangerous substances contained in this European Technical Assessment, there may be other requirements applicable to the products falling within its scope (e.g. transposed European legislation and national laws, regulations and administrative provisions). In order to meet the provisions of the Construction Products Regulation, these requirements need also to be complied with, when and where they apply.

3.3 Safety in use (BWR 4)

3.3.1 Mechanical resistance and stability

No performance assessed.

3.3.2 Resistance to impact / movement

No performance assessed.

3.3.3 Adhesion

No performance assessed.

3.4 Protection against noise (BWR 5)

3.4.1 Airborne sound insulation

No performance assessed.

3.5 Energy economy and heat retention (BWR 6)

3.5.1 Thermal properties

No performance assessed.

3.5.2 Water vapour permeability

No performance assessed.

3.6 General aspects relating to fitness for use

The inlay of “ROKU® AWM II - KS”, made of intumescent material (ROKU® Strip), fulfils the requirements for the intended use category.

“ROKU® System AWM II - KS” is therefore appropriate for use in conditions exposed to weathering, and can therefore – according to ETAG 026-Part 2 clause 2.4.12.1.3.3 – be categorized as Type X. Since the requirements for Type X are met, also the requirements for Type Y₁, Y₂, Z₁ and Z₂ are fulfilled.

It is assumed that the sheet steel housing of “ROKU® AWM II - KS” is sufficiently protected against corrosion by the used type of powder coating.

4 Assessment and verification of constancy of performance (hereinafter AVCP) system applied, with reference to its legal base

4.1 AVCP system

According to the Decision 1999/454/EC⁶, amended by Decision 2001/596/EC⁷ of the European Commission the system(s) of assessment and verification of constancy of performance (see Annex V of Regulation (EU) No 305/2011) is given in the following table.

Product(s)	Intended use(s)	Level(s) or class(es) (resistance to fire)	System of assessment and verification of constancy of performance
Fire Stopping and Fire Sealing Products	for fire compartmentation and/or fire protection or fire performance	any	1

⁶ Official Journal of the European Communities no. L 178, 14.7.1999, p. 52

⁷ Official Journal of the European Communities no. L 209, 2.8.2001, p. 33

In addition, according to the Decision 1999/454/EC, amended by Decision 2001/596/EC of the European Commission the system(s) of assessment and verification of constancy of performance, with regard to reaction to fire, is given in the following table.

Product(s)	Intended use(s)	Level(s) or class(es) (reaction to fire)	System of assessment and verification of constancy of performance
Fire Stopping and Fire Sealing Products	for uses subject to regulations on reaction to fire	A1*, A2*, B*, C*	1
		A1**, A2**, B**, C**, D, E	3
		(A1 to E)***, F	4
<p>* Products/materials for which a clearly identifiable stage in the production process results in an improvement of the reaction to fire classification (e.g. an addition of fire retardants or a limiting of organic material)</p> <p>** Products/materials not covered by footnote (*)</p> <p>*** Products/materials that do not require to be tested for reaction to fire (e.g. products/materials of class A1 according to Commission Decision 96/603/EC, as amended)</p>			

5 Technical details necessary for the implementation of the AVCP system, as provided for the applicable European Assessment Document

Technical details necessary for the implementation of the AVCP system are laid down in the control plan deposited with the Technical Assessment Body Österreichisches Institut für Bautechnik.

The notified product certification body shall visit the factory at least once a year for surveillance of the manufacturer.

Issued in Vienna on 01.09.2017
by Österreichisches Institut für Bautechnik

The original document is signed by:

Rainer Mikulits
Managing Director

electronic copy electronic copy electronic copy electronic copy electronic copy electronic copy electronic copy electronic copy electronic copy electronic copy

2 Details for installation of “ROKU® System AWM II - KS” (see Annex B-1 to F-4 of the ETA)

- > “ROKU® System AWM II - KS” has to be installed according to the ETA-holder’s installation instructions.
- > Conduits and conduit bundles have to be equipped with “ROKU® AWM II - KS”.
- > The smallest pipe collar corresponding to the relevant outer diameter of the conduit or conduit bundles to be sealed off has to be used (see Annex B-1 and Annex C-1 to Annex F-4 of the ETA).
- > For conduits and conduit bundles the annular gap between the conduit or the conduit bundle and the active component (ROKU® Strip) of the pipe collar has to be maximum 15 mm (see Annex C-1, Annex C-2 and Annex E-1 of the ETA).
- > The minimum length of conduits and conduit bundles on both sides of the separating element has to be 200 mm (measured from the surface of the separating element).
- > In vertical separating elements the pipe collars have to be installed on both sides of the separating element.
- > In horizontal separating elements the pipe collars have to be installed at the bottom side of the separating element.
- > The annular gap between the cable(s) and the conduit has to be filled to a depth of minimum 10 mm on both sides of the separating element with “ROKU® AC Brandschutzkitt“ or “Kerafix® Brandschutzsilikon”.
- > Empty conduits have to be filled to a depth of minimum 10 mm on both sides of the separating element with “ROKU® AC Brandschutzkitt“ or “Kerafix® Brandschutzsilikon”.

2.1 Fixing

- > Conduit bundles in horizontal separating elements have to be fixed (bound together) on at least the bottom side of the separating element with at least one winding of winding wire (steel wire with a diameter of $\geq 1,5$ mm) or plastic wire at maximum 100 mm (measured from the surface of the separating element).
- > In flexible walls the pipe collars have to be fixed by threaded steel bolts (thread size M6 for type DN 32 to DN 75 or thread size M8 for type DN 90 to DN 125, corresponding to the diameter of the bores within the fixing lugs; length \geq thickness of the separating element) and on both sides of the separating element with washers and nuts (corresponding to the outer diameter of the threaded steel bolts).
- > In rigid walls and rigid floors the pipe collars have to be fixed by appropriate steel dowels (outer diameter ≥ 6 mm) resp. steel screw anchors (outer diameter $\geq 7,5$ mm) and washers (corresponding to the outer diameter of the steel dowels resp. steel screw anchors).
- > The number of fixing lugs shall not be reduced.

ROKU® System AWM II - KS
- Details for installation -

ANNEX A-2

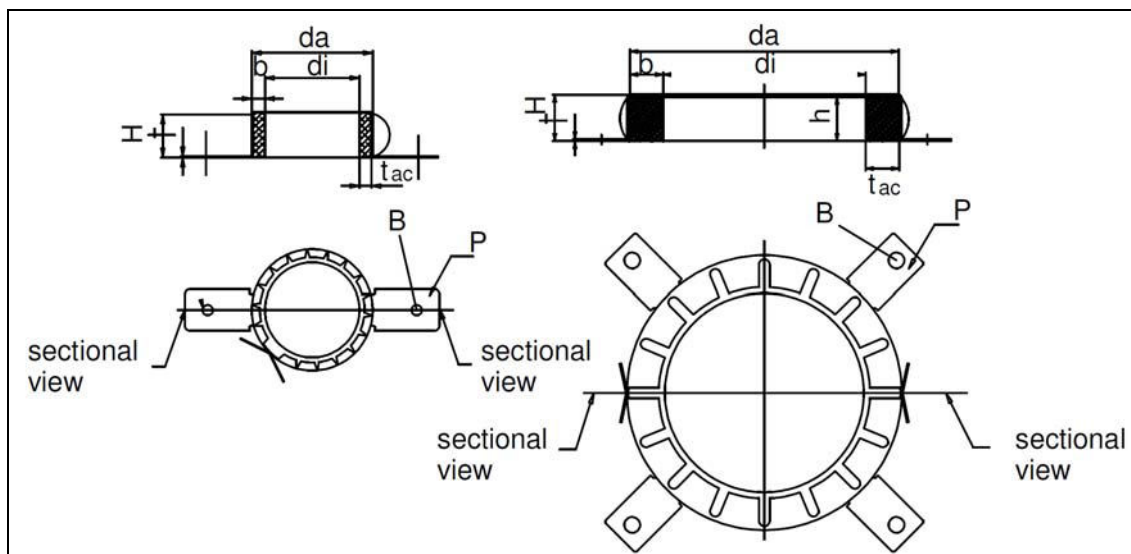

type (DN)	collar					active component		fixing lugs	
	di (mm)	da (mm)	H (mm)	t (mm)	b (mm)	t _{ac} (mm)	h (mm)	P (pcs)	B (mm)
63	67	94	26,0	0,6	13,5	12,8 ± 1,0	25,4	4	6,0
75	79	106	26,0	0,6	13,5	12,8 ± 1,0	25,4	4	6,0
90	94	132	26,6	1,1	18,3	19,2 ± 1,0	25,4	4	9,0
110	114	155	26,6	1,1	20,5	19,2 ± 1,5	25,4	4	9,0
125	129	172	40,0	1,1	28,0	25,6 -0/+2,0	38,1	4	9,0

di...inner diameter of collar
da...outer diameter of collar
H...height of collar
t...thickness of sheet steel
b...width of sheet steel
t_{ac}...thickness of active component
h...height of active component
P...number of fixing lugs
B...diameter of bores
dimensions of fixing lugs 35 mm x 20 mm (length x width)

ROKU® System AWM II - KS
- Description of "ROKU® AWM II - KS" -

ANNEX B-1

Bundles of plastic conduits (including single penetrations) acc. to cl. 2.1 of the ETA – in flexible walls with a thickness ≥ 94 mm and rigid walls with a thickness ≥ 100 mm acc. to cl. 2.1 of the ETA – ROKU® AWM II - KS installed on both sides of the separating element – Installation drawing – sectional view

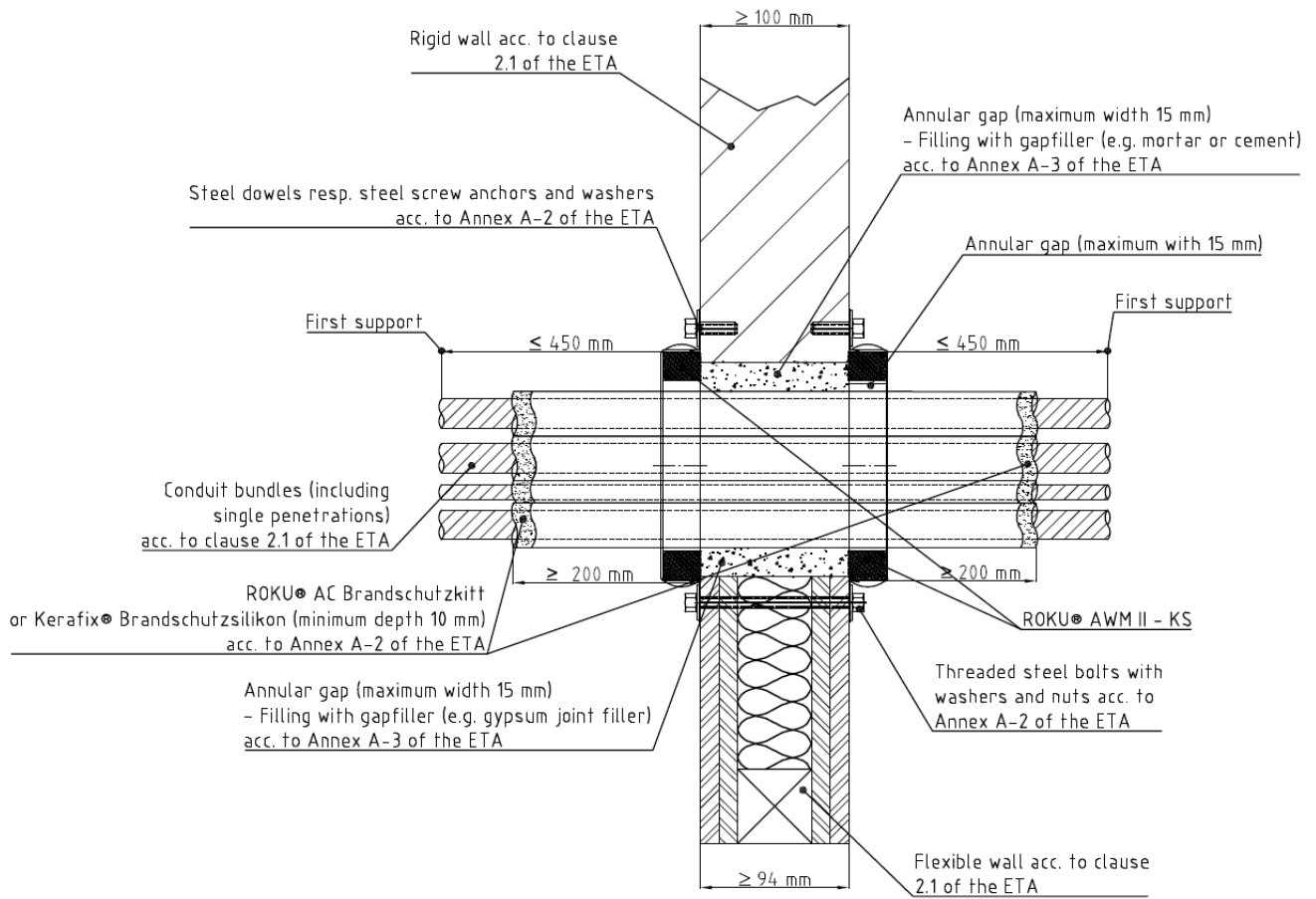

ROKU® System AWM II - KS
- Installation in flexible wall and rigid wall -

ANNEX C-1

Bundles of plastic conduits (including single penetrations) acc. to cl. 2.1 of the ETA – in rigid walls with a thickness ≥ 150 mm acc. to cl. 2.1 of the ETA – ROKU® AWM II - KS installed on both sides of the separating element – Installation drawing – sectional view

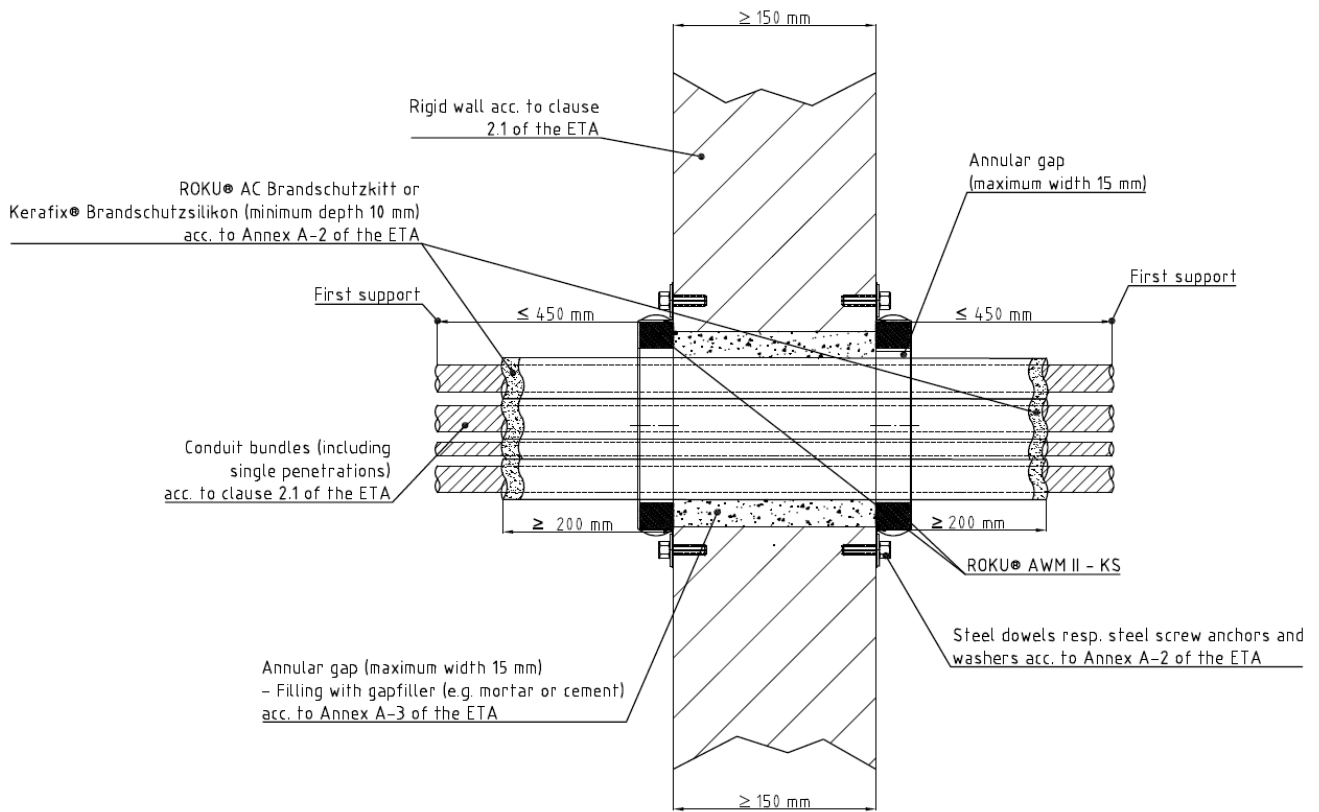

ROKU® System AWM II - KS
- Installation in rigid wall -

ANNEX C-2

Bundles of plastic conduits (including single penetrations) acc. to cl. 2.1 of the ETA – in flexible walls with a thickness ≥ 94 mm and rigid walls with a thickness ≥ 100 mm acc. to cl. 2.1 of the ETA – “ROKU[®] AWM II - KS” installed on both sides of the separating element			
Bundles of plastic conduits “FFKuS-EM-F Highspeed” made of PVC-U (with cables $\varnothing \leq 21$ mm) containing conduits with the following dimensions		Pipe collar	Fire resistance classification
Outer diameter (mm)	Wave height (mm)	“ROKU[®] AWM II - KS” type (DN)	
16	2,55	63	EI 120 E 120
20	2,90		
40	4,35		
50	5,00		
63	6,25		
16	2,55	75	EI 120 E 120
20	2,90		
63	6,25		

ROKU[®] System AWM II - KS
- Fire resistance classification -

ANNEX D-1

electronic copy electronic copy electronic copy electronic copy electronic copy electronic copy electronic copy electronic copy

Bundles of plastic conduits (including single penetrations) acc. to cl. 2.1 of the ETA – in flexible walls with a thickness ≥ 94 mm and rigid walls with a thickness ≥ 100 mm acc. to cl. 2.1 of the ETA – “ROKU® AWM II - KS” installed on both sides of the separating element			
Bundles of plastic conduits “FFKuS-EM-F-105 Highspeed” made of polyolefine (with cables $\varnothing \leq 21$ mm) containing conduits with the following dimensions		Pipe collar	Fire resistance classification
Outer diameter (mm)	Wave height (mm)	“ROKU® AWM II - KS” type (DN)	
16	2,80	63	EI 120 E 120
20	3,20		
40	5,00		
50	5,60		
63	7,10		
16	2,80	75	EI 120 E 120
20	3,20		
63	7,10		
ROKU® System AWM II - KS		ANNEX D-3	
- Fire resistance classification -			

electronic copy electronic copy electronic copy electronic copy electronic copy electronic copy electronic copy electronic copy electronic copy electronic copy

Bundles of plastic conduits (including single penetrations) acc. to cl. 2.1 of the ETA – in flexible walls with a thickness ≥ 94 mm and rigid walls with a thickness ≥ 100 mm acc. to cl. 2.1 of the ETA – “ROKU® AWM II - KS” installed on both sides of the separating element			
Bundles of plastic conduits “FFKuS-EM-F-105 Highspeed” made of polyolefine (without cables $\varnothing \leq 21$ mm) containing conduits with the following dimensions		Pipe collar	Fire resistance classification
Outer diameter (mm)	Wave height (mm)	“ROKU® AWM II - KS” type (DN)	
16	2,80	63	EI 120 E 120
20	3,20		
40	5,00		
63	7,10		
16	2,80	75	EI 120 E 120
20	3,20		
63	7,10		
ROKU® System AWM II - KS		ANNEX D-4	
- Fire resistance classification -			

electronic copy electronic copy electronic copy electronic copy electronic copy electronic copy electronic copy electronic copy electronic copy electronic copy

Bundles of plastic conduits (including single penetrations) acc. to cl. 2.1 of the ETA – in rigid walls with a thickness ≥ 150 mm acc. to cl. 2.1 of the ETA – “ROKU® AWM II - KS” installed on both sides of the separating element			
Bundles of plastic conduits “FFKuS-EM-F Highspeed” made of PVC-U (with cables $\varnothing \leq 21$ mm) containing conduits with the following dimensions		Pipe collar	Fire resistance classification
Outer diameter (mm)	Wave height (mm)	“ROKU® AWM II - KS” type (DN)	
16	2,55	90	EI 120 E 120
20	2,90		
25	3,20		
32	3,85		
40	4,35		
50	5,00		
63	6,25		
16	2,55	110	EI 120 E 120
20	2,90		
25	3,20		
32	3,85		
40	4,35		
50	5,00		
63	6,25		
16	2,55	125	EI 120 E 120
20	2,90		
25	3,20		
32	3,85		
40	4,35		
50	5,00		
63	6,25		

ROKU® System AWM II - KS - Fire resistance classification -	ANNEX D-5
--	------------------

electronic copy electronic copy electronic copy electronic copy electronic copy electronic copy electronic copy electronic copy electronic copy electronic copy

Bundles of plastic conduits (including single penetrations) acc. to cl. 2.1 of the ETA – ETA – in rigid walls with a thickness ≥ 150 mm – “ROKU® AWM II - KS” installed on both sides of the separating element			
Bundles of plastic conduits “FFKuS-EM-F Highspeed” made of PVC-U (without cables $\varnothing \leq 21$ mm) containing conduits with the following dimensions		Pipe collar	Fire resistance classification
Outer diameter (mm)	Wave height (mm)	“ROKU® AWM II - KS” type (DN)	
16	2,55	90	EI 120 E 120
20	2,90		
25	3,20		
32	3,85		
40	4,35		
50	5,00		
63	6,25		
16	2,55	110	EI 120 E 120
20	2,90		
25	3,20		
32	3,85		
40	4,35		
50	5,00		
63	6,25		
16	2,55	125	EI 120 E 120
20	2,90		
25	3,20		
32	3,85		
40	4,35		
50	5,00		
63	6,25		

ROKU® System AWM II - KS - Fire resistance classification -	ANNEX D-6
--	------------------

electronic copy electronic copy electronic copy electronic copy electronic copy electronic copy electronic copy electronic copy electronic copy electronic copy

Bundles of plastic conduits (including single penetrations) acc. to cl. 2.1 of the ETA – in rigid walls with a thickness ≥ 150 mm acc. to cl. 2.1 of the ETA – “ROKU® AWM II - KS” installed on both sides of the separating element			
Bundles of plastic conduits “FFKuS-EM-F-105 Highspeed” made of polyolefine (with cables $\varnothing \leq 21$ mm) containing conduits with the following dimensions		Pipe collar	Fire resistance classification
Outer diameter (mm)	Wave height (mm)	“ROKU® AWM II - KS” type (DN)	
16	2,80	90	EI 120 E 120
20	3,20		
25	3,55		
32	4,30		
40	5,00		
50	5,60		
63	7,10		
16	2,80	110	EI 120 E 120
20	3,20		
25	3,55		
32	4,30		
40	5,00		
50	5,60		
63	7,10		
16	2,80	125	EI 120 E 120
20	3,20		
25	3,55		
32	4,30		
40	5,00		
50	5,60		
63	7,10		

ROKU® System AWM II - KS - Fire resistance classification -	ANNEX D-7
--	------------------

electronic copy electronic copy electronic copy electronic copy electronic copy electronic copy electronic copy electronic copy electronic copy electronic copy

Bundles of plastic conduits (including single penetrations) acc. to cl. 2.1 of the ETA – in rigid walls with a thickness ≥ 150 mm acc. to cl. 2.1 of the ETA – “ROKU® AWM II - KS” installed on both sides of the separating element			
Bundles of plastic conduits “FFKuS-EM-F-105 Highspeed” made of polyolefine (without cables $\varnothing \leq 21$ mm) containing conduits with the following dimensions		Pipe collar	Fire resistance classification
Outer diameter (mm)	Wave height (mm)	“ROKU® AWM II - KS” type (DN)	
16	2,80	90	EI 120 E 120
20	3,20		
25	3,55		
32	4,30		
40	5,00		
50	5,60		
63	7,10		
16	2,80	110	EI 120 E 120
20	3,20		
25	3,55		
32	4,30		
40	5,00		
50	5,60		
63	7,10		
16	2,80	125	EI 120 E 120
20	3,20		
25	3,55		
32	4,30		
40	5,00		
50	5,60		
63	7,10		

ROKU® System AWM II - KS - Fire resistance classification -	ANNEX D-8
--	------------------

Bundles of plastic conduits (including single penetrations) acc. to cl. 2.1 of the ETA – in rigid floors with a thickness ≥ 150 mm acc. to cl. 2.1 of the ETA – ROKU® AWM II - KS installed on the bottom side of the separating element – installation drawing – sectional view

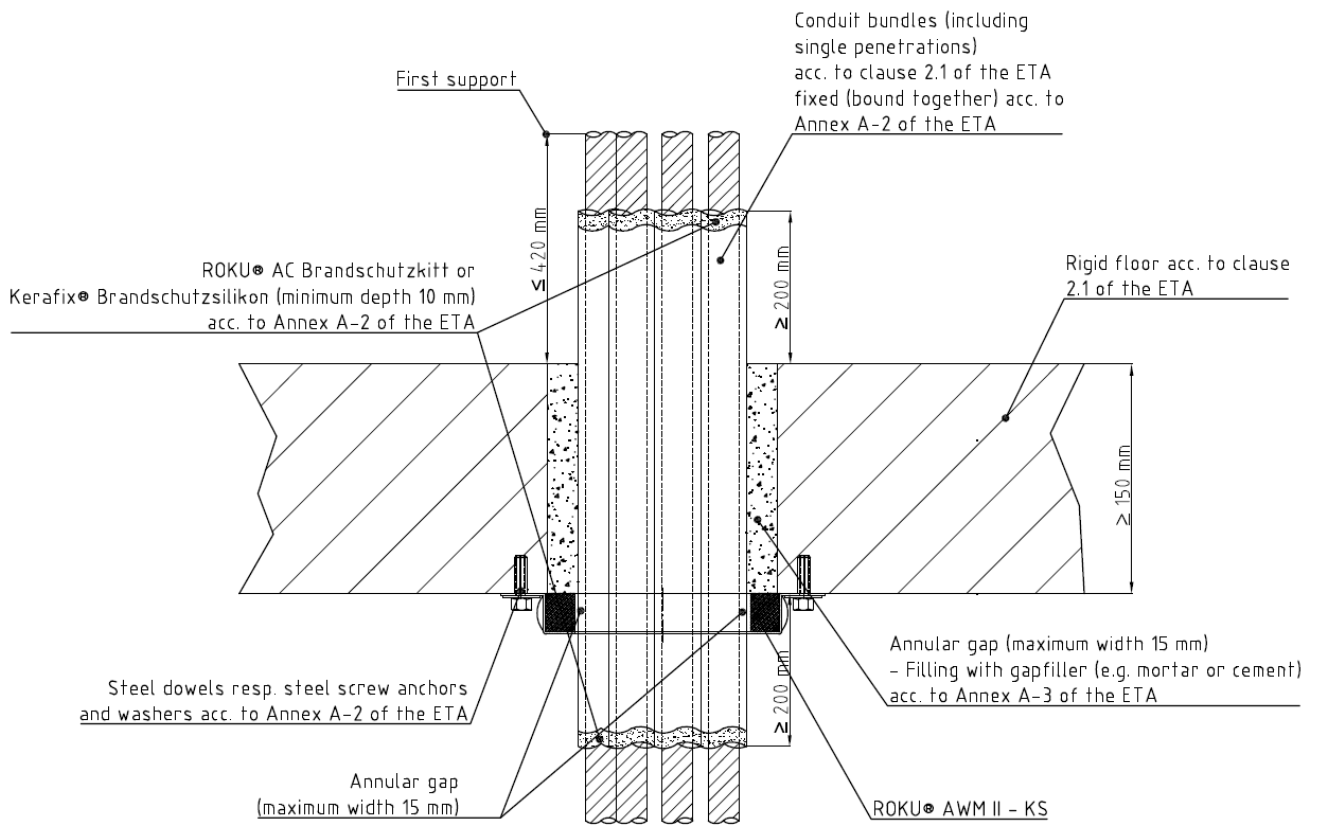

ROKU® System AWM II - KS
- Installation in rigid floor -

ANNEX E-1

electronic copy

Bundles of plastic conduits (including single penetrations) acc. to cl. 2.1 of the ETA – in rigid floors with a thickness ≥ 150 mm acc. to cl. 2.1 of the ETA – “ROKU® AWM II - KS” installed on the bottom side of the separating element			
Bundles of plastic conduits “FFKuS-EM-F Highspeed” made of PVC-U (with cables $\varnothing \leq 21$ mm) containing conduits with the following dimensions		Pipe collar	Fire resistance classification
Outer diameter (mm)	Wave height (mm)	“ROKU® AWM II - KS” type (DN)	
16	2,55	63	EI 120 E 120
20	2,90		
40	4,35		
50	5,00		
63	6,25		
16	2,55	75	EI 120 E 120
20	2,90		
63	6,25		
16	2,55	90	EI 120 E 120
20	2,90		
25	3,20		
32	3,85		
40	4,35		
50	5,00		
63	6,25		
16	2,55	110	EI 120 E 120
20	2,90		
25	3,20		
32	3,85		
40	4,35		
50	5,00		
63	6,25		
16	2,55	125	EI 120 E 120
20	2,90		
25	3,20		
32	3,85		
40	4,35		
50	5,00		
63	6,25		

ROKU® System AWM II - KS
- Fire resistance classification -

ANNEX F-1

electronic copy

Bundles of plastic conduits (including single penetrations) acc. to cl. 2.1 of the ETA – in rigid floors with a thickness ≥ 150 mm acc. to cl. 2.1 of the ETA – “ROKU® AWM II - KS” installed on the bottom side of the separating element			
Bundles of plastic conduits “FFKuS-EM-F Highspeed” made of PVC-U (without cables $\varnothing \leq 21$ mm) containing conduits with the following dimensions		Pipe collar	Fire resistance classification
Outer diameter (mm)	Wave height (mm)	“ROKU® AWM II - KS” type (DN)	
16	2,55	63	EI 120 E 120
20	2,90		
40	4,35		
50	5,00		
63	6,25		
16	2,55	75	EI 120 E 120
20	2,90		
63	6,25		
16	2,55	90	EI 120 E 120
20	2,90		
25	3,20		
32	3,85		
40	4,35		
50	5,00		
63	6,25		
16	2,55	110	EI 120 E 120
20	2,90		
25	3,20		
32	3,85		
40	4,35		
50	5,00		
63	6,25		
16	2,55	125	EI 120 E 120
20	2,90		
25	3,20		
32	3,85		
40	4,35		
50	5,00		
63	6,25		

ROKU® System AWM II - KS
- Fire resistance classification -

ANNEX F-2

electronic copy

Bundles of plastic conduits (including single penetrations) acc. to cl. 2.1 of the ETA – in rigid floors with a thickness ≥ 150 mm acc. to cl. 2.1 of the ETA – “ROKU® AWM II - KS” installed on the bottom side of the separating element			
Bundles of plastic conduits “FFKuS-EM-F-105 Highspeed” made of polyolefine (with cables $\varnothing \leq 21$ mm) containing conduits with the following dimensions		Pipe collar	Fire resistance classification
Outer diameter (mm)	Wave height (mm)	“ROKU® AWM II - KS” type (DN)	
16	2,80	63	EI 120 E 120
20	3,20		
40	5,00		
50	5,60		
63	7,10		
16	2,80	75	EI 120 E 120
20	3,20		
63	7,10		
16	3,20	90	EI 120 E 120
20	3,55		
25	4,30		
32	5,00		
40	5,60		
50	7,10		
63	2,80		
16	2,80	110	EI 120 E 120
20	3,20		
25	3,55		
32	4,30		
40	5,00		
50	5,60		
63	7,10		
16	2,80	125	EI 120 E 120
20	3,20		
25	3,55		
32	4,30		
40	5,00		
50	5,60		
63	7,10		

ROKU® System AWM II - KS
- Fire resistance classification -

ANNEX F-3

electronic copy electronic copy electronic copy electronic copy electronic copy electronic copy electronic copy electronic copy electronic copy electronic copy

Bundles of plastic conduits (including single penetrations) acc. to cl. 2.1 of the ETA – in rigid floors with a thickness ≥ 150 mm acc. to cl. 2.1 of the ETA – “ROKU® AWM II - KS” installed on the bottom side of the separating element			
Bundles of plastic conduits “FFKuS-EM-F-105 Highspeed” made of polyolefine (without cables $\varnothing \leq 21$ mm) containing conduits with the following dimensions		Pipe collar	Fire resistance classification
Outer diameter (mm)	Wave height (mm)	“ROKU® AWM II - KS” type (DN)	
16	2,80	63	EI 120 E 120
20	3,20		
40	5,00		
50	5,60		
63	7,10		
16	2,80	75	EI 120 E 120
20	3,20		
63	7,10		
16	2,80	90	EI 120 E 120
20	3,20		
25	3,55		
32	4,30		
40	5,00		
50	5,60		
63	7,10		
16	2,80	110	EI 120 E 120
20	3,20		
25	3,55		
32	4,30		
40	5,00		
50	5,60		
63	7,10		
16	2,80	125	EI 120 E 120
20	3,20		
25	3,55		
32	4,30		
40	5,00		
50	5,60		
63	7,10		

ROKU® System AWM II - KS
- Fire resistance classification -

ANNEX F-4